

**References, Abbreviations, and Definitions**  
**(New)**

## REFERENCES, ABBREVIATIONS, AND DEFINITIONS

### General:

1. This section establishes standard references, abbreviations, and definitions applicable throughout the City's Design Requirements and Standard Plans, as well as its policies, collectively referred to herein as "Westminster Standard Plans."
2. The reference standards listed below are external technical standards, regulations, and/or specifications that are incorporated by reference and establish minimum requirements for the design, materials, construction, testing, and inspection of public and private improvements within the City. Compliance is mandatory when they are referenced in the Westminster Standard Plans.
3. Reference standards shall include the latest edition, incorporating all revisions, amendments, supplements, or addenda issued on or before the date of permit issuance or bid opening.
4. When conflicts arise between referenced standards and the Westminster Standard Plans, the latter shall take precedence unless explicitly directed otherwise by the City Engineer.

### Reference Standards:

#### Regional/State:

1. California State Water Resources Control Board (SWRCB)
2. Cal/OSHA, Title 8, CCR – Construction Safety Orders
3. California Waterworks Standards, Title 22, CCR
4. California Manual on Uniform Traffic Control Devices (California MUTCD)
5. Caltrans Standard Plans and Standard Specifications
6. Orange County Fire Authority (OCFA)
7. Orange County Health Care Agency, Environmental Health Division (OCHCA)
8. City of Westminster Code of Ordinances
9. Standard Specifications for Public Works Construction ("Greenbook")
10. American Water Works Association (AWWA) Standards

Industry and National:

1. ANSI/ASME – dimensional and mechanical standards where referenced.
2. AMPP (formerly NACE) – corrosion control standards (e.g., cathodic protection, coatings).
3. APWA – Uniform Color Code for utility marking.
4. ASTM International – material and testing standards.
5. NSF/ANSI/CAN 61 – Drinking Water System Components – Health Effects (potable contact materials).
6. NSF/ANSI/CAN 372 – Drinking Water System Components – Lead Content.

PROPOSED

**DEPARTMENT OF PUBLIC WORKS**

**ABBREVIATIONS:**

Unless the context requires otherwise, the following abbreviations shall mean as follows:

<b>AC</b>	ASPHALT-CONCRETE	<b>CORP</b>	CORPORATION
<b>ACP</b>	ASBESTOS-CEMENT PIPE	<b>COUP</b>	COUPLING
<b>ADU</b>	ACCESSORY DWELLING UNIT	<b>CYL</b>	CYLINDER
<b>AHJ</b>	AUTHORITY HAVING JURISDICTION	<b>DCA</b>	DOUBLE CHECK VALVE
<b>ANSI</b>	AMERICAN NATIONAL STANDARDS INSTITUTE	<b>DCDA</b>	DOUBLE CHECK DETECTOR ASSEMBLY
<b>APWA</b>	AMERICAN PUBLIC WORKS ASSOCIATION	<b>DI or DIP</b>	DUCTILE-IRON PIPE
<b>API</b>	AMERICAN PETROLEUM INSTITUTE	<b>DIA</b>	DIAMETER
<b>ASTM</b>	AMERICAN STANDARD TEST METHOD	<b>DET</b>	DETAIL
<b>AWWA</b>	AMERICAN WATER WORKS ASSOCIATION	<b>EA</b>	EACH
<b>BFV</b>	BUTTERFLY VALVE	<b>EX.</b>	EXISTING
<b>BPA</b>	BACKFLOW PREVENTION ASSEMBLY	<b>ELEC</b>	ELECTRIC OR ELECTRICAL
<b>C.A.B</b>	CRUSHED AGGREGATE BASE	<b>ELL</b>	ELECTRIC OR ELECTRICAL
<b>CI or CIP</b>	CAST-IRON PIPE	<b>FLG</b>	FLANGE
<b>CC</b>	CENTER TO CENTER	<b>FIP</b>	FEMALE IRON PIPE
<b>CCR</b>	CALIFORNIA CODE OF REGULATIONS	<b>FH</b>	FIRE HYDRANT
<b>CL</b>	CENTERLINE	<b>FS</b>	FINISHED SURFACE
<b>CL</b>	CLASS	<b>G</b>	GAS
<b>CLR</b>	CLEARANCE	<b>GA</b>	GAUGE, GAGE
<b>CMC</b>	CEMENT-MORTAR COATED	<b>GALV</b>	GALVANIZED
<b>CML</b>	CEMENT-MORTAR LINED	<b>GPS</b>	GLOBAL POSITIONING SYSTEM
<b>CONC.</b>	CONCRETE	<b>GIS</b>	GEOGRAPHIC INFORMATION SYSTEM
		<b>HDPE</b>	HIGH-DENSITY POLYETHYLENE
		<b>HGL</b>	HYDRAULIC GRADE LINE
		<b>HPFH</b>	HIGH PRESSURE FIRE HYDRANT
		<b>ID</b>	INSIDE DIAMETER
		<b>IP</b>	IRON PIPE
		<b>JADU</b>	JUNIOR ACCESSORY DWELLING UNIT

City of Westminster

**DEPARTMENT OF PUBLIC WORKS**

<b>LBS</b>	POUNDS	<b>REP.</b>	REPAIR
<b>LG</b>	LONG	<b>REQD</b>	REQUIRED
<b>MAX</b>	MAXIMUM	<b>RWQCB</b>	REGIONAL WATER QUALITY CONTROL BOARD
<b>MCM</b>	THOUSAND CIRCULAR MILS (1 MIL IS 0.001 INCH)	<b>R/W</b>	RIGHT-OF-WAY
<b>MIN</b>	MINIMUM	<b>SCH</b>	SCHEDULE NO.
<b>MJ</b>	MECHANICAL JOINT	<b>SPECS</b>	SPECIFICATIONS
<b>MIL</b>	MILLILITER	<b>SQ</b>	SQUARE
<b>MV</b>	MILLIVOLTS	<b>SS</b>	SANITARY SEWER
<b>NC</b>	NORMALLY CLOSED	<b>SSPWC</b>	STANDARD SPECIFICATIONS FOR PUBLIC WORKS CONSTRUCTION (GREENBOOK)
<b>NO</b>	NORMALLY OPEN		
<b>NO.</b>	NUMBER		
<b>NTS</b>	NOT TO SCALE	<b>S STL</b>	STAINLESS STEEL
<b>OD</b>	OUTSIDE DIAMETER	<b>STD</b>	STANDARD
<b>OC</b>	ON CENTER	<b>STL</b>	STEEL
<b>OCFA</b>	ORANGE COUNTY FIRE AUTHORITY	<b>TYP</b>	TYPICAL
<b>OCHCA</b>	ORANGE COUNTY HEALTH CARE AGENCY	<b>VAR</b>	VARIES
		<b>WWP</b>	WATER WORKING PRESSURE
		<b>W/</b>	WITH
<b>O&amp;M</b>	OPERATIONS & MAINTENANCE		
<b>PE</b>	POLYETHYLENE		
<b>PL</b>	PROPERTY LINE		
<b>PCC</b>	PORTLAND CEMENT CONCRETE		
<b>PR</b>	PRESSURE RATING		
<b>PRV</b>	PRESSURE REDUCING VALVE		
<b>PSV</b>	PRESSURE SAFETY VALVE		
<b>PSF</b>	POUNDS PER SQUARE FOOT		
<b>PSI</b>	POUNDS PER SQUARE INCH		
<b>PVB</b>	PRESSURE VACUUM BREAKER		
<b>PVC</b>	POLYVINYL CHLORIDE		
<b>RAD</b>	RADIUS		
<b>REINF.</b>	REINFORCE OR REINFORCING		

**DEFINITIONS:**

Unless the context requires otherwise, the following definitions shall mean as follows:

**DEFINITIONS: CONTRACT AND ADMINISTRATION**

- A. **Addendum:** Pre-bid instrument modifying procurement documents.
- B. **Approved/Accepted:** Written acknowledgement from the Engineer or designee that a submittal or Work item meets the Contract intent.
- C. **Approved Equal:** A product, material, or system that (a) is demonstrably equivalent in function, performance, durability, dimensions, service life, warranty, and code compliance to the specified item, and (b) has received the written approval of the Engineer or designee.
- D. **Authority Having Jurisdiction (AHJ):** Regulatory body with legal authority over the Work (e.g., OCHCA, OCFA, City Building Official, RWQCB).
- E. **Change Directive (CD)/Plan Clarification:** A written directive from the Engineer or designee to clarify or modify Work prior to a formal Change Order.
- F. **Change Order (CO):** A written modification to the contract sum, time, or scope after execution of the Agreement.
- G. **Contract Documents:** The Agreement, General Conditions, Special Provisions, approved Addenda, Drawings, Specifications, and written Modifications/Change Orders.
- H. **Contractor:** Any Contractor who meets the City's requirements to perform the work of installing water lines under the City's jurisdiction.
- I. **Design Engineer:** The licensed Professional Engineer in the state of California responsible for the engineering design of the proposed water system or its components.
- J. **Engineer:** City Engineer, or other person designated by the Council or City Manager's office, acting either directly or through authorized agents.
- K. **Final Completion:** All Work complete and accepted, including punch list and closeout deliverables (as-builts, O&M manuals, warranties).
- L. **Inspector:** Owner's authorized field representative to observe, test, and accept Work.
- M. **Notice to Proceed (NTP):** Written authorization establishing the start of Contract Time.
- N. **Owner (City):** City of Westminster, acting through its authorized representatives, including the Water Division.
- O. **Record Drawings (As-Builts):** Drawings reflecting actual installed conditions, red-lined and submitted as CAD/PDF as required.
- P. **Request for Information (RFI):** Contractor's written request for clarification of the Contract Documents.

**PUBLIC WORKS DEPARTMENT**

- Q. **Substantial Completion:** Stage when the Work is sufficiently complete for its intended use, as certified by the Engineer or designee.
- R. **Work:** The entire construction and services required by the Contract Documents.

DEFINITIONS: WATER SYSTEM COMPONENTS

- A. **Air Release Valve (ARV)/Air Vacuum Valve (AVV)/Combination Air Valve (CAV):** A valve that releases entrained air, admits air under vacuum, or both.
- B. **Angle Meter Stop/Curb Stop:** Valve controlling flow at the meter or property line.
- C. **Backflow Prevention Assembly (BPA):** Device preventing reverse flow; types include RP, DC, PVB, SVB, DCDA; assemblies shall be approved by the City's Cross-Connection Control Specialist and OCHCA.
- D. **Blowoff Assembly (BO):** Appurtenance for flushing and draining pipelines.
- E. **Butterfly Valve (BFV):** Quarter-turn isolation/control valve for larger diameters.
- F. **Check Valve (CV):** Prevents reverse flow (swing, double-disc, silent types).
- G. **Corporation Stop:** Valve tapping the main that connects to the service lateral.
- H. **Fire Hydrant Assembly:** Hydrant, valve, fittings, and lead per City Standard Details and OCFA requirements.
- I. **Fittings:** Bends, tees, reducers, sleeves, and specials used to route and connect piping.
- J. **Gate Valve (GV):** Resilient-seated isolation valve for buried service.
- K. **Potable Water:** Water meeting all applicable drinking-water standards.
- L. **Pressure Reducing Valve (PRV):** Regulates downstream pressure to a setpoint.
- M. **Pressure Sustaining/Relief Valve (PSV):** Maintains minimum upstream pressure or relieves excess.
- N. **Recycled (Non-Potable) Water:** Treated wastewater for approved non-potable uses; identification by purple (violet) color per City Standard and or California Title 22 requirements.
- O. **Service Lateral (Service Line):** Pipeline from the main to the customer meter or service point.
- P. **Valve (General):** Flow-control device (gate, butterfly, check, PRV, PSV, altitude, air valve; as shown on Drawings).
- Q. **Water Main or Pipeline:** Distribution pipeline conveying water to service areas, and shall include all mainlines, branches, and service laterals above 2-inch diameter in size.
- R. **Water Meter/Meter Box/Vault:** Device and housing to measure usage and provide access.

DEFINITIONS: PIPE MATERIALS AND JOINTS

- A. **Cathodic Protection (CP):** Corrosion control using galvanic anodes or impress current; design and installation per AMPP/NACE standards when required.
- B. **Copper Tube (Type K):** Copper service tubing for laterals/service connections.
- C. **Ductile Iron Pipe (DIP):** AWWA C151 pressure pipe with linings/coatings per Drawings; polyethylene encasement per AWWA C105 where indicated.
- D. **HDPE:** AWWA/ASTM pressure-rated high-density polyethylene pipe with heat-fused joints.
- E. **Insulating Flange Kit:** Isolates pipeline electrical continuity for CP compatibility.
- F. **Joint Types:** Push-on, Mechanical Joint (MJ), flanged, restrained joint, and fused joints as specified.
- G. **Lining/Coating:** Interior/exterior protective systems (e.g., cement-mortar, fusion-bonded epoxy) compatible with service and disinfection chemicals.
- H. **Polyethylene Encasement (PE):** Loose-fit wrap for DIP corrosion control per AWWA C105.
- I. **PVC Pressure Pipe:** AWWA C900/C905 pipe with pressure class and DR per Drawings.
- J. **Restraint:** Restrained joints, restraint glands, or other devices to resist hydraulic thrust as indicated.
- K. **Steel Pipe:** Welded steel with specified linings/coatings (e.g., cement mortar, epoxy).
- L. **Thrust Block:** Concrete bearing block resisting hydraulic thrust at changes in direction or fittings.
- M. **Tracer Wire/Test Station:** Conductive wire and access points for locating non-metallic pipelines.

DEFINITIONS: CONSTRUCTION AND INSTALLATION

- A. **Bedding/Initial Backfill/Final Backfill:** Materials and placements providing support, pipe envelope, and restoration per Specifications and City Standard Details.
- B. **Compaction (Relative Compaction):** In-place soil density relative to a standard; percent per Specifications (e.g., 90–95% as indicated).
- C. **Cover:** Vertical distance from finished grade to top of pipe; minimum cover per Drawings and City standards.
- D. **Deflection:** Angular change at joints; shall not exceed manufacturer/specification limits.
- E. **Dig Alert (811):** Utility notification and locate service prior to excavation; Contractor shall comply with notification timelines and marking requirements.
- F. **Hot Tap/Wet Tap:** Pressurized connection to an active main using a tapping sleeve/valve assembly.
- G. **Line Stop/Insertion Valve:** Temporary/permanent device to stop flow without full shutdown.
- H. **Mandrel Test:** Ovality testing for flexible pipe (e.g., PVC) after backfill settlement per Specifications.

**PUBLIC WORKS DEPARTMENT**

- I. **Pavement Restoration:** Trench and surface replacement per City Standard Details and permits (T-cut, full-depth, or as specified).
- J. **Separation (Clearances):** Minimum horizontal and vertical distances from sewers and other utilities per California Waterworks Standards and OCHCA policy or more stringent City requirements.
- K. **Tie-In/Cut-In:** Connection of new facilities to existing systems, typically via planned shutdown procedures.
- L. **Trench/Shoring/Shield:** Excavation and protective systems per Cal/OSHA and Section 31 requirements.
- M. **Utility Potholing:** Vacuum or hand excavation to positively locate existing utilities prior to work.
- N. **Warning (Marking) Tape:** Detectable/non-detectable colored tape placed above utilities per APWA color code and City details.

DEFINITIONS: TESTING, DISINFECTION, AND COMMISSIONING

- A. **Bacteriological Sampling:** Laboratory testing (e.g., total coliform, E. coli) with acceptance criteria per OCHCA and applicable standards.
- B. **Dechlorination:** Chemical or physical removal of chlorine prior to discharge; must meet NPDES permit limits.
- C. **Disinfection (Chlorination):** Cleaning and chlorinating new or repaired facilities per AWWA C651; includes required contact time and concentration.
- D. **Fire Flow Test:** Measured available flow and residual pressure per the OCFA method, when required.
- E. **Flushing/Swabbing:** High-velocity flushing and/or mechanical cleaning prior to disinfection and sampling.
- F. **Free Chlorine:** Free available chlorine is the amount of chlorine available as dissolved gas that is not combined with ammonia (NH<sub>3</sub>) or other compounds and is available for disinfection. Free chlorine is a faster-reacting disinfectant than other forms of chlorine.
- G. **Hydraulic Grade Line (HGL):** Water surface elevation represents the system energy grade line for pressure systems.
- H. **Hydrostatic Pressure Test:** Pressure integrity test per applicable AWWA standard (e.g., C600/C605/C651) and Drawings.
- I. **Leakage Test:** Measurement of allowable leakage during pressure testing per AWWA and Specifications.
- J. **Pressure Zone:** Defined network area operating at a similar hydraulic grade line.
- K. **Total Chlorine:** Total chlorine refers to the amount of chlorine present, including both free chlorine and combined chlorine. It still has disinfecting abilities; however, it reacts more slowly than Free Chlorine.

DEFINITIONS: SAFETY, ENVIRONMENTAL, AND TRAFFIC

- A. **Best Management Practices (BMPs):** Erosion, sediment, and pollution control measures per SWPPP and City requirements.
- B. **Confined Space (Permit-Required):** Space meeting criteria requiring entry permits and controls per Cal/OSHA.
- C. **Dewatering:** Temporary removal/control of groundwater; includes discharge permitting and treatment as required by RWQCB/NPDES.
- D. **SPCC (if applicable):** Spill Prevention, Control, and Countermeasure plan for stored fuels/oils.
- E. **Traffic Control Plan (TCP):** Site-specific plan for temporary traffic control per California MUTCD and City permits.

DEFINITIONS: SURVEY, EASEMENTS, AND PERMISSIONS

- A. **Access Agreement:** Permission to enter private property when not covered by an easement.
- B. **Benchmark/Control:** Vertical and horizontal survey control points referenced on the Drawings.
- C. **Easement:** Recorded right to construct, access, and maintain facilities on private property.
- D. **Encroachment Permit:** Authorization to perform Work within public rights-of-way or other jurisdictions; includes City and, where applicable, Caltrans.
- E. **Right-of-Way (R/W):** Land or easement dedicated to the City for public utilities/transportation.
- F. **Stationing:** Linear referencing system along project alignment.

DEFINITIONS: PLANS AND PROCEDURES

- A. **Bypass Plan:** Temporary conveyance to maintain service during construction.
- B. **Shutdown Plan:** A written plan for isolations, customer notifications, valving, and contingencies for tie-ins; approved by the Engineer or designee.
- C. **Startup/Commissioning Plan:** Stepwise process to place facilities into service, including testing and acceptance criteria.
- D. **SWPPP:** Storm Water Pollution Prevention Plan describing BMPs and inspections when required by the permits.
- E. **Outage Notification:** Required communication to affected customers and stakeholders prior to service interruptions per City policy.

## **Traffic Control General Notes**

**TRAFFIC CONTROL GENERAL NOTES**

1. These standard notes and plans shall not relieve the contractor of the responsibility for jobsite conditions during ~~the course of~~ construction or maintenance work, including the safety of all persons, vehicles, and property.
  
2. All work, materials, practices, and principles shall comply with the Caltrans Standard Plans and Specifications, the latest edition, the California Manual of Uniform Traffic Control Devices (CA MUTCD), the latest edition, and the Work Area Traffic Control Handbook (WATCH), the latest edition.
  
3. The California Manual of Uniform Traffic Control Devices (CA MUTCD), latest edition, and the Work Area Traffic Control Handbook (WATCH), latest edition, shall take precedence in the event of any question regarding the control of these standards.
  
4. Traffic Control Plans prepared by a registered traffic engineer or registered civil engineer in the ~~state~~State of California may be required if the complexity of the construction and its corresponding traffic control ~~exceed~~exceeds the content of these standards.
  
5. No deviations or exceptions from these standard notes or plans shall be allowed without prior approval from the Public Works Director/City Engineer.
  
6. Construction or maintenance ~~activity in~~activities on the roadway or affecting the public right-of-way shall be limited to the hours between 8:30 AM and 4:00 PM. No temporary traffic devices shall be placed in the roadway ~~until after~~before 8:30 AM and ~~shall~~must be completely removed by 4:00 PM. All excavation areas shall be completely covered with steel plates (~~with that have~~ a non-skid slip surface) and be recessed if ~~they are placed~~located on primary ~~and or~~ secondary highways, as directed by the Public Works Director/City Engineer. Excavation ~~are~~sites may also be temporarily backfilled and surfaced ~~such so~~ that all lanes of traffic are restored and fully accessible to the public at the end of each day, unless otherwise authorized. Refer to Standard Plan No. 609 for additional requirements.

7. Cones and delineators shall generally be placed on existing lane lines, except as necessary for lane closure tapers.
8. All striping and markings shall conform to the California Manual of Uniform Traffic Control Devices (CA MUTCD), latest edition.
9. All conflicting striping, markings, and legends shall be completely removed by an approved method prior to any change in the traffic pattern.
10. All existing signingsigns shall be protected in place and be free from ~~obstructed view for obstruction to~~ traffic. ~~In the event that~~ view. If existing ~~signing is contradictory to signage conflicts with~~ temporary ~~signing for~~ construction signs, the contractor shall either ~~completely~~fully cover the existing signingsigns or remove ~~the signing and them, along with their~~ supporting posts ~~entirely~~, and install new signingsigns and supports ~~at the conclusion of~~after construction ~~activities is~~ complete.
11. The contractor shall be responsible for notifying the adjacent property owners.
12. The contractor shall provide access to all adjacent properties at all times except as necessary for construction activities in the immediate vicinity of the work area.
13. Construction operations shall be conducted in a manner such that as little inconvenience as possible is caused to the public and abutting property owners.
14. The contractor shall have all signs, delineators, barricades, etc., properly installed prior to construction.
15. The contractor shall be responsible for maintaining, at all times, all signs, delineators, barricades, etc., to ensure proper flow and safety of traffic.

16. A minimum lane width of ~~10'~~10 feet must be maintained at all times, with no exceptions. When ~~adjacent~~next to a curb lane, raised curb medians, other vertical ~~obstruction~~obstructions, or opposing traffic, the minimum lane width ~~shall be 12'~~increases to 12 feet.
17. The contractor shall ~~utilize flag men~~use flagmen during work hours as required by these standard plans and as deemed necessary by the City to ~~assist in maintaining~~help maintain safe traffic flow.
18. Flashing arrow ~~signs (FAS)~~board (FAB) shall be used for all lane closures and shall be solar powered.
19. The first sign in a series of advanced warning signs shall be equipped with flags.
20. Flashing yellow beacons, Type B, shall be used on all barricades that protect the work area and on the first sign in a series of advanced warning signs, after normal working hours.
21. All signs shall be reflectorized and of standard sizes.
22. The contractor shall be required to ~~replace~~restore striping, pavement markings, and legends to their original condition ~~and equipment~~ after ~~completion of~~completing construction.
23. All delineators shall be 36" minimum portable, reflectorized rubber guide post tubes, that are orange in color, with weighted bases or sandbag rings ~~and~~. They shall be kept in their proper position at all times, and ~~shall~~must be repaired, replaced, or cleaned as ~~necessary~~needed to ~~preserve~~maintain their appearance and ~~continuity~~effectiveness.
24. All cones, shall be 28" minimum, orange in color, and shall be kept in their proper ~~position~~positions at all times, ~~and~~. They shall be repaired, replaced, or cleaned as ~~necessary~~needed to ~~preserve~~maintain their appearance and ~~continuity~~effectiveness. All cones shall be ~~fitted~~equipped with at least 13" minimum-inch reflective sleeves for nighttime traffic control. ~~Maximum spacing~~The maximum distance between ~~delineators~~cones shall be 25'25 feet.

25. At least every third cone and/or delineator shall have delineator or cone-mounted directional arrows per the Work Area Traffic Control Handbook (WATCH) ~~),~~ latest edition.
26. Barricades shall be used, in lieu of or in addition to rubber ~~guide posts~~guideposts, as required by these standard plans and at the direction of the City Engineer or designee, when they are intended to provide additional emphasis in areas where workers are present.
27. C27 (CA) "OPEN TRENCH" signs shall be used in conjunction with Type II barricades during construction and nighttime closures as applicable.
28. Where lights are used to delineate the traveled way through and around the work area, they shall be Type C (steady burn lamps).
29. When a street closure is approved, the contractor shall notify the Police Department, the Fire Department, the local transit district, affected residents, and businesses at least one (1) week in advance of the closure.
30. All residential street access restricted by construction or maintenance activities shall be restored at the end of each working day unless otherwise approved by the Public Works Director/City Engineer.
31. Temporary "NO STOPPING" signs shall be posted 100' apart, as necessary, during construction operations. When a temporary "NO STOPPING" zone on a street is approved by the City's representative, the contractor shall notify the Police Department and post "TOW AWAY, TEMPORARY NO STOPPING" at least ~~two (2) working days~~72 hours in advance. The duration of the temporary parking restriction shall be indicated on the signs.

## TRAFFIC CONTROL GENERAL NOTES (CONTINUED)

32. When signal timing ~~and/or signal~~ modifications are ~~necessary~~needed before or during ~~the~~ construction, and if approved by the City's Traffic Engineer, the contractor shall notify the City by calling (714) 548-~~34623457~~ at least three (3) working days ~~in advance of prior to~~ the work to ~~be done in order to~~ coordinate the changes. The contractor shall provide the personnel and equipment required to ~~make perform~~ the signal modifications; ~~the, and~~ City ~~shall make will implement~~ the necessary signal timing ~~changes~~adjustments.
33. Contractor shall replace all traffic detection devices, signing, striping, markings, and legends damaged during construction to the satisfaction of the City's representative.
34. These plans indicate traffic control in the work area during construction activities. Additional traffic controls, traffic signs, and/or barricades may be necessary or required in the field. The contractor shall be responsible for the placement of any additional devices necessary, as directed by the City's representative, to assure ensure public safety ~~to the public~~ at all times during construction.
35. Contractor shall comply with the requirements of the ~~American Disability~~Americans with Disabilities Act (ADA) ~~as~~ related to pedestrian access and shall maintain pedestrian access at all times ~~per~~ in accordance with ADA requirements.
36. Install Temporary No Parking Signs (if required) 72 hours prior to the closure.
37. Notification is required at 714-530-6060 at least 36 hours prior to construction and must be acknowledged by the Orange County Transportation Authority (OCTA) dispatch if an OCTA bus stop is to be impacted.

\*\*\*End of Traffic Control General Notes\*\*\*

**TRAFFIC CONTROL GENERAL NOTES**

1. These standard notes and plans shall not relieve the contractor of the responsibility for jobsite conditions during construction or maintenance work, including the safety of all persons, vehicles, and property.
2. All work, materials, practices, and principles shall comply with the Caltrans Standard Plans and Specifications, the latest edition, the California Manual of Uniform Traffic Control Devices (CA MUTCD), the latest edition, and the Work Area Traffic Control Handbook (WATCH), the latest edition.
3. The California Manual of Uniform Traffic Control Devices (CA MUTCD), latest edition, and the Work Area Traffic Control Handbook (WATCH), latest edition, shall take precedence in the event of any question regarding the control of these standards.
4. Traffic Control Plans prepared by a registered traffic engineer or registered civil engineer in the State of California may be required if the complexity of the construction and its corresponding traffic control exceeds the content of these standards.
5. No deviations or exceptions from these standard notes or plans shall be allowed without prior approval from the City Engineer.
6. Construction or maintenance activities on the roadway or affecting the public right-of-way shall be limited to the hours between 8:30 AM and 4:00 PM. No temporary traffic devices shall be placed in the roadway before 8:30 AM and must be completely removed by 4:00 PM. All excavation areas shall be completely covered with steel plates that have a non-slip surface and be recessed if located on primary or secondary highways, as directed by the City Engineer. Excavation sites may also be temporarily backfilled and surfaced so that all lanes of traffic are restored and fully accessible to the public at the end of each day, unless otherwise authorized. Refer to Standard Plan No. 609 for additional requirements.
7. Cones and delineators shall generally be placed on existing lane lines, except as necessary for lane closure tapers.
8. All striping and markings shall conform to the California Manual of Uniform Traffic Control Devices (CA MUTCD), latest edition.
9. All conflicting striping, markings, and legends shall be completely removed by an approved method prior to any change in the traffic pattern.
10. All existing signs shall be protected in place and be free from obstructing the view of traffic. If existing signage conflicts with temporary construction signs, the contractor shall either fully cover the existing signs or remove them, along with their supporting posts, and install new signs and supports after construction is complete.
11. The contractor shall be responsible for notifying the adjacent property owners.
12. The contractor shall provide access to all adjacent properties at all times except as necessary for construction activities in the immediate vicinity of the work area.

**DEPARTMENT OF PUBLIC WORKS**

13. Construction operations shall be conducted in a manner such that as little inconvenience as possible is caused to the public and abutting property owners.
14. The contractor shall have all signs, delineators, barricades, etc., properly installed prior to construction.
15. The contractor shall be responsible for maintaining, at all times, all signs, delineators, barricades, etc., to ensure proper flow and safety of traffic.
16. A minimum lane width of 10 feet must be maintained at all times, with no exceptions. When next to a curb lane, raised curb medians, other vertical obstructions, or opposing traffic, the minimum lane width increases to 12 feet.
17. The contractor shall use flagmen during work hours as required by these standard plans and as deemed necessary by the City to help maintain safe traffic flow.
18. Flashing arrow boards (FAB) shall be used for all lane closures and shall be solar powered.
19. The first sign in a series of advanced warning signs shall be equipped with flags.
20. Flashing yellow beacons, Type B, shall be used on all barricades that protect the work area and on the first sign in a series of advanced warning signs, after normal working hours.
21. All signs shall be reflectorized and of standard sizes.
22. The contractor shall be required to restore striping, pavement markings, and legends to their original condition after completing construction.
23. All delineators shall be 36 inches minimum, portable, reflectorized rubber guide post tubes that are orange in color, with weighted bases or sandbag rings. They shall be kept in their proper position at all times and must be repaired, replaced, or cleaned as needed to maintain their appearance and effectiveness.
24. All cones shall be 28 inches minimum, orange in color, and shall be kept in their proper positions at all times. They shall be repaired, replaced, or cleaned as needed to maintain their appearance and effectiveness. All cones shall be equipped with at least 13-inch reflective sleeves for nighttime traffic control. The maximum distance between cones shall be 25 feet.
25. At least every third cone and/or delineator shall have delineator or cone-mounted directional arrows per the Work Area Traffic Control Handbook (WATCH), latest edition.
26. Barricades shall be used, in lieu of or in addition to rubber guideposts, as required by these standard plans and at the direction of the City Engineer or designee, when they are intended to provide additional emphasis in areas where workers are present.
27. C27 (CA) "OPEN TRENCH" signs shall be used in conjunction with Type II barricades during construction and nighttime closures as applicable.
28. Where lights are used to delineate the traveled way through and around the work area, they shall be Type C (steady burn lamps).

**DEPARTMENT OF PUBLIC WORKS**

29. When a street closure is approved, the contractor shall notify the Police Department, the Fire Department, the local transit district, affected residents, and businesses at least one (1) week in advance of the closure.
30. All residential street access restricted by construction or maintenance activities shall be restored at the end of each working day unless otherwise approved by the City Engineer.
31. Temporary "NO STOPPING" signs shall be posted 100 feet apart, as necessary, during construction operations. When a temporary "NO STOPPING" zone on a street is approved by the City's representative, the contractor shall notify the Police Department and post "TOW AWAY, TEMPORARY NO STOPPING" at least 72 hours in advance. The duration of the temporary parking restriction shall be indicated on the signs.
32. When signal timing or modifications are needed before or during construction, and if approved by the City's Traffic Engineer, the contractor shall notify the City by calling (714) 548-3457 at least three (3) working days prior to the work to coordinate the changes. The contractor shall provide the personnel and equipment required to perform the signal modifications, and the City will implement the necessary signal timing adjustments.
33. Contractor shall replace all traffic detection devices, signing, striping, markings, and legends damaged during construction to the satisfaction of the City's representative.
34. These plans indicate traffic control in the work area during construction activities. Additional traffic control, traffic signs, and/or barricades may be necessary or required in the field. The contractor shall be responsible for the placement of any additional devices necessary, as directed by the City's representative, to ensure public safety at all times during construction.
35. Contractor shall comply with the requirements of the Americans with Disabilities Act (ADA) related to pedestrian access and shall maintain pedestrian access at all times in accordance with ADA requirements.
36. Notification of the Orange County Transportation Authority (OCTA) is required at (714) 530-6060 at least 36 hours prior to construction and must be acknowledged by OCTA dispatch if an OCTA bus stop is to be impacted.

\*\*\*End of Traffic Control General Notes\*\*\*

## **Traffic Sign & Striping Notes**

TRAFFIC SIGN & STRIPING NOTES

1. All existing signs shall ~~remain be protected in place~~ unless shown otherwise on the plans or directed ~~differently~~ by the City's Traffic Engineer.
- ~~2. Pavement marking stencils shall match City stencils exactly.~~
- ~~2. All striping and~~ All signing, striping, pavement legend, and pavement marking shall comply with the latest edition of the California Manual of Uniform Traffic Control Devices (CA MUTCD), Caltrans Standard Plans and Specifications, and City of Westminster Standard Plans.
3. All striping, pavement legend, and pavement marking ~~that do~~ not ~~conforming~~ conform to the approved striping plans shall be removed or as directed by the City's Traffic Engineer. Removal shall be performed by wet sandblasting or grinding a rectangular area, completely obliterating the marking.
4. Striping layout shall be approved by the ~~engineer~~ City's Traffic Engineer prior to final painting. Contact the Traffic Engineer ~~Engineering Department at (714) 548-3457 for approval~~ before "CAT-TRACKING". The contractor shall remove and reinstall the temporary striping taps if they are more than 6" apart from the approved "cat-track."
- ~~5. All striping shall consist of paint and raised pavement markers per the details on the approved striping plans, and the California Manual on Uniform Traffic Control Devices (MUTCD) unless otherwise shown.~~
- ~~6.5. All striping shall be beaded per Caltrans standards. Two and two (2) coats of paint are required. All paint shall be lead-free, waterborne paint. On new pavement, the second coat shall be applied within 7 to 14 days after the first coat.~~
- ~~6. Temporary striping taps shall not remain on the pavement for more than ten (10) days and shall be removed when the first coat of paint is installed.~~
7. All pavement legends, pavement markings, and crosswalks shall be thermoplastic, consisting of 3M reflective elements, and shall allow for both wet and dry reflectivity.
8. The contractor shall ~~place~~ install a blue retroreflective raised pavement marker in the roadway at each fire hydrant location for the entire length of the project per direction of the City's Traffic Engineer.
9. Unless otherwise shown on the plans, all lane lines shall be parallel to the street centerline.
10. All dimensions for lane widths are to the center of the stripe and the face of the curb.
11. ~~Splice~~ All new loop ~~detectors to~~ detector wires shall be spliced into existing lead-in cables ~~in pull boxes.~~

12. Paint the first three (3) feet of all raised medians with reflective paint. Paint shall be white or as directed by the City's Traffic Engineer.
13. All traffic loop detector installations shall have a minimum of 7/8" cover.
14. All "CAT-TRACKING" shall be placed prior to loop installation.
15. ~~Place left~~Left-turn pocket ~~per~~shall be installed according to City of Westminster Standard Plan No. 507.
16. Crosswalks shall have ten (10) feet between ~~twelve~~12-inch stripes and shall start at half-delta unless otherwise dimensioned.
17. Yellow reflective markers shall be offset 2" inches from all stripes ~~per~~according to the latest Caltrans Standard Plan A20A and A20B ~~Detail~~Details 22, 29, and 32 (~~no reflective~~non-retroreflective markers shall be placed on the stripes).
18. All curb paintings shall be removed ~~using~~by the wet/~~hydro~~sand blasting method and subsequently repainted to match ~~with~~the existing markings for the entire length of the project.
19. All arterial streets shall be posted with no stop signs, R26(S)(CA), where applicable. Signage locations shall be approved by the City's Traffic Engineer prior to installation.
20. New signpost shall be a perforated square steel tube (PSST) with a two-piece anchor and sleeve, "telespar." The bottom of the lowest signs shall have a clearance of a minimum of seven (7) feet from the finished sidewalk surface.
21. Signs larger than 48 inches or locations where sidewalks are less than five (5) feet wide, the signpost shall be installed behind the back of the sidewalk and approved by the City's Traffic Engineer.
22. At the intersection of all collector streets, all striping details shall begin at the "End of Curb Return" (ECR) and end at the "Begin of Curb Return" (BCR).

\*\*\*End of Traffic Sign & Striping Notes\*\*\*

18.

**TRAFFIC SIGN & STRIPING NOTES**

1. All existing signs shall be protected in place unless shown otherwise on the plans or directed by the City's Traffic Engineer.
2. All signing, striping, pavement legend, and pavement marking shall comply with the latest edition of the California Manual of Uniform Traffic Control Devices (CA MUTCD), Caltrans Standard Plans and Specifications, and City of Westminster Standard Plans.
3. All striping, pavement legend, and pavement marking that do not conform to the approved striping plans shall be removed or as directed by the City's Traffic Engineer. Removal shall be performed by wet sandblasting or grinding a rectangular area, completely obliterating the marking.
4. Striping layout shall be approved by the City's Traffic Engineer prior to final painting. Contact the traffic engineering department at (714) 548-3457 for approval before "CAT-TRACKING." The contractor shall remove and reinstall the temporary striping taps if they are more than 6" apart from the approved "cat-track."
5. All striping shall consist of raised pavement markers and two (2) coats of paint. All paint shall be lead-free, waterborne paint. On new pavement, the second coat shall be applied within 7 to 14 days after the first coat.
6. Temporary striping taps shall not remain on the pavement for more than ten (10) days and shall be removed when the first coat of paint is installed.
7. All pavement legends, pavement markings, and crosswalks shall be thermoplastic, consisting of 3M reflective elements, and shall allow for both wet and dry reflectivity.
8. The contractor shall install a blue retroreflective raised pavement marker in the roadway at each fire hydrant location for the entire length of the project per direction of the City's Traffic Engineer.
9. Unless otherwise shown on the plans, all lane lines shall be parallel to the street centerline.
10. All dimensions for lane widths are to the center of the stripe and the face of the curb.
11. All new loop detector wires shall be spliced into existing lead-in cables.
12. Paint the first three (3) feet of all raised medians with reflective paint. Paint shall be white or as directed by the City's Traffic Engineer.
13. All traffic loop detector installations shall have a minimum of 7/8" cover.
14. All "CAT-TRACKING" shall be placed prior to loop installation.
15. Left-turn pocket shall be installed according to City of Westminster Standard Plan No. 507.
16. Crosswalks shall have ten (10) feet between 12-inch stripes and shall start at half-delta unless otherwise dimensioned.

17. Yellow reflective markers shall be offset 2 inches from all stripes according to the latest Caltrans Standard Plan A20A and A20B Details 22, 29, and 32 (non-retroreflective markers shall be placed on the stripes).
18. All curb paintings shall be removed by the wet sand blasting method and subsequently repainted to match the existing markings for the entire length of the project.
19. All arterial streets shall be posted with no stop signs, R26(S)(CA), where applicable. Signage locations shall be approved by the City's Traffic Engineer prior to installation.
20. New signpost shall be a perforated square steel tube (PSST) with a two-piece anchor and sleeve, "telespar." The bottom of the lowest signs shall have a clearance of a minimum of seven (7) feet from the finished sidewalk surface.
21. Signs larger than 48 inches or locations where sidewalks are less than five (5) feet wide, the signpost shall be installed behind the back of the sidewalk and approved by the City's Traffic Engineer.
22. At the intersection of all collector streets, all striping details shall begin at the "End of Curb Return" (ECR) and end at the "Begin of Curb Return" (BCR).

\*\*\*End of Traffic Sign & Striping Notes\*\*\*

## **Water Notes**

## Water Notes

~~1. All materials shall conform to the latest revision of AWWA Standards. Construction shall be per the latest edition of the Standard Specifications for Public Works Construction, including any supplements or the City of Westminster Standard Plans.~~

### WATER NOTES

~~2.1.~~ All alternatives to any ~~portion~~part of these specifications must be approved in writing at least forty-eight (48) hours ~~before bid date or any~~prior to the start of construction.

~~3.2.~~ For Residential Tracts: Upon installing residential, commercial, and industrial properties, when water meters ~~for new houses, are installed, the~~ developer shall ~~obtain~~establish billing accounts for ~~all meters. Developer shall be~~ each meter and remain responsible for ~~payments on new meter water charges until ownership is transferred to a new owner~~ purchases the or until a commercial or industrial property ~~is sold or leased to a new owner or tenant.~~ All newly installed meters shall be "new" ~~or not previously used.~~ All new meters and unused and shall have ~~"register a "0" reading upon at the time of installation.~~ Any meter reading on newly installed meter shall be treated as used water upon establishment of new ~~obtained at the start of a new~~ billing account and shall be added to the ~~will be regarded as water already used and will be included in the initial billing fee.~~ No water usage ~~shall~~may be ~~allowed~~drawn from an ~~un-metered~~any unmetered source for any purpose. ~~Developer shall obtain a temporary~~ reason. All ~~construction water meter if needed to use water from a fire hydrant~~related Commercial/Industrial Properties: Upon installing meters, developer shall obtain billing accounts for all meters. Developer shall be responsible for payments until new owner purchases the property, or new tenant leases the property. All newly installed meters shall be "new" or not previously used. All new meters shall have "0" reading upon installation. Any reading on a newly installed meter shall be treated as used water upon establishment of new water billing account and shall be added to the initial billing fee. No water usage shall be allowed from an un-metered source for any purpose. Developer shall ~~obtain~~use must be supplied through a temporary construction water meter ~~if needed to use water from a~~ obtained by the developer and connected to a City fire hydrant.

3. Meter size calculations shall be based on the latest edition of the California Plumbing Code and shall be approved by the City of Westminster Building Department.

4. All Multi-Family Residential, Commercial, Industrial, Hotel/Motel, and Institutional developments shall have a dedicated irrigation service with a properly sized water meter.

5. For ~~All New Construction/Industrial Developments: Developer shall contact the all new~~ construction and industrial projects, the developer shall consult the Water Division's Cross-Connection Control Specialist ~~in the Water Division to obtain~~to secure approval ~~of all~~for any proposed backflow prevention devices.
6. ~~All 1"~~The placement of new water services and meters is subject to approval by the Water Division. It shall be ~~Drisco pipe~~ located within the City of Westminster Right-of-Way, positioned away from driveway approaches and ADA accessible paths unless prior approval is obtained from the Water Division and or the City Engineer.
7. ~~No water service taps shall be made under driveway approaches. Water meter boxes must retain a minimum clearance of three feet from any driveway approach, and all service lines shall run perpendicularly from the water main to the meter without any bends.~~
8. ~~1", IPS 200-psi PE 3408-inch and 2-inch water service taps shall have a minimum spacing of 24 inches and be staggered around the pipe's circumference. 4-inch and 6-inch taps shall have a minimum spacing of 48 inches, and 8-inch and larger taps shall have a minimum spacing of 60 inches.~~
- ~~6.9.~~All 1-inch water services shall be Rehau Municipex SDR9 (CTS) Part #261076, or approved equal-, with Ford Stainless Steel Insert 52 on both ends. A plastic-coated 14-gauge copper tracer wire shall be installed as shown on City Standard #Plan Nos. 401-A and 401-B.
10. ~~All 1-inch residential water services supplying both domestic and fire water shall be constructed according to City Standard Plan No. 401-B.~~
- ~~7.11.~~ All 2-inch water services shall be ~~Drisco pipe 2", I.P.S. 200-psi P.E., 2-inch Rehau Municipex SDR9 (CTS) part #261136, or approved equal. Riser~~an approved equivalent, with a Ford Stainless Steel Insert 55 on both ends. Rigid copper tubing type "K" may be used for laterals shorter than 20 feet, with Water Division approval, and shall have no joints. The riser shall be rigid copper tubing type "K". A 14-gauge plastic-coated copper tracer wire shall be installed as shown on City Standard #Plan No. 413.
- ~~8.12.~~ All water meters shall be lead-free bronze, magnetic drive, touch-read meters. ~~Meters 3/4", configured to 2" will read in 100 cubic feet and meters 4" to 6" to read in 500 cubic feet. Meter type will be iPERL® for 3/4" to 1"; OMNI™ for 1.5" to 2" and . All meters must be verified before installation~~inspected by the Water Division before installation.

- a. ¾" and 1" meters shall be iPERL® Metal with TR/PL Housing and 2-wire iPERL pigtail.
- b. 1 ½" meters shall be OMNI+ C2 100CF with TR/PL Housing.
- c. 2" meters shall be OMNI+ C2T2 Body 100CF, with TR/PL Housing.
- d. 3" and above meters shall be OMNI+ C2 with TR/PL Housing

~~9.13.~~ Water meter boxes shall be ~~J & R polymer with J & R polymer covers~~ Hubbell Armorcast or an approved equal, as specified within the City of Westminster Standard Plans. Covers to be fitted for touch-read or approved equal as per City Standard #401. No #3 size meter boxes will be used without Water Division approval. ~~read technology.~~

~~40.14.~~ Gate valves shall be Mueller Series A ~~2360~~2362 resilient wedge, ~~250 psig working pressure, 500 psig test pressure, with Class 125, with stainless-steel fasteners, low zinc stem, and shear stem, or approved equal.~~ Valves to be installed per City Standard ~~#Plan No. 403-A.~~

~~44.15.~~ Butterfly valves shall be ~~Pratt~~ Groundhog or approved equal. Butterfly valves shall conform to ANSI/AWWA C504 and shall be flanged, and of the size and class indicated. Flanged valves shall have 125-lb or 250-lb flanges complying with ANSI B16.5. ~~Valves may be either short-bodied or long-bodied except as otherwise indicated.~~ 1 with 316 stainless-steel fasteners. Shaft seals shall be designed for use with standard split-V type packing or other approved seals, and the interior passage shall not have any excessive obstructions or stops. Cartridge-type valve seats, or valves employing snap rings to retain the rubber seats, will not be acceptable. The rubber seat shall be mounted in the valve body.

## Water Notes (Continue)

~~42.16.~~ Butterfly valves shall be installed with the operating stem on the street centerline side.

~~43.17.~~ Gate and butterfly valves shall be located at ~~BCR's~~BCRs of streets unless otherwise specified.

~~44.18.~~ Iron fittings shall be cement mortar-lined and coated per AWWA Standards C110 or C153, with polyethylene encasement per AWWA C105 or otherwise specified, and be installed per City Standard #Plan No. 402.

19. All fasteners, including nuts, bolts, washers, and T-head bolts, shall be 316 Stainless Steel. Anti-seize shall be applied to prevent galling.

20. All fasteners, flanges, MJ glands, restrained joints, mechanical couplings, valves, tapping saddles, and corporation stops shall be coated with NO-OX-ID "A" special soft grease and wax tape, overlapped to ensure complete coverage. Valves, mechanical couplings, and metallic fittings shall also be encased in polyethylene in accordance with AWWA C105.

~~45.21.~~ Fire hydrants shall be Jones J-3765R, or approved equal, wet barrel, all bronze with 1 ½" operation nuts and caps. Hydrants to ~~have a~~be 6" hole with standard flange drilling per City Standard #Plan No. 404.

~~46.22.~~ All valve boxes shall be adjustable, slip cast iron boxes. Tyler 6855 series lids ~~to~~must be marked "Water". It ~~shall be~~is the contractor's responsibility ~~of the contractor~~ to raise all valve boxes to grade after paving per, in accordance with City Standard #Plan No. 403-A.

~~47.23.~~ Pre-cast concrete vaults shall be ~~J&R Concrete or Armorcast series with~~ polymer concrete vaults with torsion assist polymer concrete covers and non-skid surface fitted for touch-~~read~~ meters or approved equal.

~~48.24.~~ Approved water main pipe shall be ~~poly-vinyl~~polyvinyl chloride PVC-C900 DR-18, JM Eagle ~~BLUe BRUe~~Blue Brute™, VinylTech, Diamond Plastic, or an approved equal. All ductile iron ~~to~~pipes shall be cement mortar-lined and coated ~~with~~ polyethylene encasement per AWWA C105. A 14-gauge copper trace wire shall be placed on top of all PVC pipes and wrapped with 10 mil, 2"-inch pipe wrap ~~two times,~~ wrapped twice around the pipe at every five (5) feet.

~~19.25.~~ Plastic-coated 14-gauge copper tracer wire from the hydrant lateral and lateral service connection to tracer wires on water mains shall be stripped and tied with a brass split bolt connector. The connection to tracer wires shall be taped and completely covered with an electrical insulating coating per Section 300-5 of the National Electrical Code, latest edition.

~~20.26.~~ ~~Separation of services—all~~ All non-water utilities must ~~have~~ maintain a minimum ~~separation distance~~ of 35 feet from any Water Utility. ~~Any~~ If this distance is less ~~separation requires special permission~~ than 5 feet, explicit approval from the Water ~~Dept~~ Division is necessary.

~~21.~~ All work requiring excavations shall maintain a valid DigAlert permit in the area.

~~22.27.~~ ~~In the event work requiring~~ If excavations are near City of Westminster water utility lines, ~~excavators shall determine the~~ contractor or applicant must identify the exact subsurface locations location (depth) by hand excavation, before ~~the use of~~ using power equipment. Pipelines exposed during excavation require inspection by City of Westminster Water staff.

~~23.28.~~ Pipelines exposed during excavation require inspection by City of Westminster Water staff.

~~24.~~ Only lateral crossings are permitted within City of Westminster right of ways.

~~25.~~ other utilities shall provide a minimum of 12" clearance to be maintained between City of Westminster pipelines and any proposed improvements.

~~26.29.~~ Sand shall be used to surround the City of Westminster water pipelines with a minimum ~~42"~~ 6-inch bedding and 12-inch cover, ~~and warning.~~ Warning tape shall be ~~place~~ placed 12" inches above the pipe ~~(. No cement slurry is allowed within 12" inches of water pipelines.)~~ and/or services.

~~27.30.~~ Contractors ~~shall use caution~~ must exercise due diligence to protect ~~City of Westminster~~ existing pipelines ~~in place~~ and ~~to avoid~~ prevent encroachments or damage ~~to City of Westminster property.~~ If pipelines are damaged, In case of pipeline damage, the City of Westminster must be notified immediately ~~so that~~ to facilitate proper repairs ~~can be made~~.

~~28.~~ Any high water use facility (60 gallons per minute or greater of continuous flow) must install an approved 3" cold water positive displacement touch read meter. ~~The size and~~

DEPARTMENT OF PUBLIC WORKS

~~manufacturer of the meter to be determined by Water Division Representative prior to installation.~~

~~29. All water meters shall be located in sidewalk or parkways behind curb in the City of Westminster right of way.~~

~~30.31.~~ A three-foot clearance shall be maintained around all water mains ~~to include,~~ including water valves, fire hydrant valves, fire service valves, and water meter valves.

~~31.32. A~~ The Water Division Representative shall conduct a visual inspection ~~shall be made by Water Division Representative on~~ of all water main valves, tees, ~~90's, 45's or other pipeline~~ 90-degree and 45-degree fittings, or other pipeline components.

\*\*\*End of Water Notes\*\*\*

## WATER NOTES

1. All alternatives to any part of these specifications must be approved in writing at least forty-eight (48) hours prior to the start of construction.
2. For residential, commercial, and industrial properties, when water meters are installed, the developer shall establish billing accounts for each meter and remain responsible for water charges until ownership is transferred to a new owner or until a commercial or industrial property is sold or leased to a new owner or tenant. All newly installed meters shall be new and unused and shall register a "0" reading at the time of installation. Any meter reading obtained at the start of a new billing account will be regarded as water already used and will be included in the initial billing fee. No water may be drawn from any unmetered source for any reason. All construction-related water use must be supplied through a temporary construction water meter obtained by the developer and connected to a City fire hydrant.
3. Meter size calculations shall be based on the latest edition of the California Plumbing Code and shall be approved by the City of Westminster Building Department.
4. All Multi-Family Residential, Commercial, Industrial, Hotel/Motel, and Institutional developments shall have a dedicated irrigation service with a properly sized water meter.
5. For all new construction and industrial projects, the developer shall consult the Water Division's Cross-Connection Control Specialist to secure approval for any proposed backflow prevention devices.
6. The placement of new water services and meters is subject to approval by the Water Division. It shall be located within the City of Westminster Right-of-Way, positioned away from driveway approaches and ADA accessible paths unless prior approval is obtained from the Water Division and or the City Engineer.
7. No water service taps shall be made under driveway approaches. Water meter boxes must retain a minimum clearance of three feet from any driveway approach, and all service lines shall run perpendicularly from the water main to the meter without any bends.
8. 1-inch and 2-inch water service taps shall have a minimum spacing of 24 inches and be staggered around the pipe's circumference. 4-inch and 6-inch taps shall have a minimum spacing of 48 inches, and 8-inch and larger taps shall have a minimum spacing of 60 inches.

9. All 1-inch water services shall be Rehau Municipex SDR9 (CTS) Part #261076, or approved equal, with Ford Stainless Steel Insert 52 on both ends. A plastic-coated 14-gauge copper tracer wire shall be installed as shown on City Standard Plan Nos. 401-A and 401-B.
10. All 1-inch residential water services supplying both domestic and fire water shall be constructed according to City Standard Plan No. 401-B.
11. All 2-inch water services shall be 2-inch Rehau Municipex SDR9 (CTS) part #261136, or an approved equivalent, with a Ford Stainless Steel Insert 55 on both ends. Rigid copper tubing type "K" may be used for laterals shorter than 20 feet, with Water Division approval, and shall have no joints. The riser shall be rigid copper tubing type "K". A 14-gauge plastic-coated copper tracer wire shall be installed as shown on City Standard Plan No. 413.
12. All water meters shall be lead-free, magnetic drive, touch-read meters, configured to read in 100 cubic feet. All meters must be inspected by the Water Division before installation.
  - a.  $\frac{3}{4}$ " and 1" meters shall be iPERL® Metal with TR/PL Housing and 2-wire iPERL pigtail.
  - b. 1  $\frac{1}{2}$ " meters shall be OMNI+ C2 100CF with TR/PL Housing.
  - c. 2" meters shall be OMNI+ C2T2 Body 100CF, with TR/PL Housing.
  - d. 3" and above meters shall be OMNI+ C2 with TR/PL Housing
13. Water meter boxes shall be Hubbell Armorcast or an approved equal, as specified within the City of Westminster Standard Plans. Covers to be fitted for touch-read technology.
14. Gate valves shall be Mueller Series A 2362 resilient wedge, Class 125, with stainless-steel fasteners, low zinc stem, and shear stem, or approved equal. Valves to be installed per City Standard Plan No. 403-A.
15. Butterfly valves shall be Pratt Groundhog or approved equal. Butterfly valves shall conform to ANSI/AWWA C504 and shall be flanged and of the size and class indicated. Flanged valves shall have 125-lb or 250-lb flanges complying with ANSI B16.1 with 316 stainless-steel fasteners. Shaft seals shall be designed for use with standard split-V type packing or other approved seals, and the interior passage shall not have any excessive obstructions or stops. Cartridge-type valve seats, or valves employing snap rings to retain the rubber seats, will not be acceptable. The rubber seat shall be mounted in the valve body.
16. Butterfly valves shall be installed with the operating stem on the street centerline side.

17. Gate and butterfly valves shall be located at BCRs of streets unless otherwise specified.
18. Iron fittings shall be cement mortar-lined and coated per AWWA Standards C110 or C153, with polyethylene encasement per AWWA C105 or otherwise specified, and be installed per City Standard Plan No. 402.
19. All fasteners, including nuts, bolts, washers, and T-head bolts, shall be 316 Stainless Steel. Anti-seize shall be applied to prevent galling.
20. All fasteners, flanges, MJ glands, restrained joints, mechanical couplings, valves, tapping saddles, and corporation stops shall be coated with NO-OX-ID "A" special soft grease and wax tape, overlapped to ensure complete coverage. Valves, mechanical couplings, and metallic fittings shall also be encased in polyethylene in accordance with AWWA C105.
21. Fire hydrants shall be Jones J-3765R, or approved equal, wet barrel, all bronze with 1 ½" operation nuts and caps. Hydrants to be 6" hole with standard flange drilling per City Standard Plan No. 404.
22. All valve boxes shall be adjustable slip cast iron boxes. Tyler 6855 series lids must be marked "Water." It is the contractor's responsibility to raise all valve boxes to grade after paving, in accordance with City Standard Plan No. 403-A.
23. Pre-cast concrete vaults shall be Armorcast polymer concrete vaults with torsion assist polymer concrete covers and non-skid surface fitted for touch-read meters or approved equal.
24. Approved water main pipe shall be polyvinyl chloride PVC-C900 DR-18, JM Eagle Blue Brute™, VinylTech, Diamond Plastic, or an approved equal. All ductile iron pipes shall be cement mortar-lined and coated with polyethylene encasement per AWWA C105. A 14-gauge copper trace wire shall be placed on top of all PVC pipes and wrapped with 10 mil 2-inch pipe wrap, wrapped twice around the pipe at every five (5) feet.
25. Plastic-coated 14-gauge copper tracer wire from the hydrant lateral and lateral service connection to tracer wires on water mains shall be stripped and tied with a brass split bolt connector. The connection to tracer wires shall be taped and completely covered with an electrical insulating coating per Section 300-5 of the National Electrical Code, latest edition.

26. All non-water utilities must maintain a minimum distance of 5 feet from any Water Utility. If this distance is less than 5 feet, explicit approval from the Water Division is necessary.
27. All work requiring excavations shall maintain a valid DigAlert permit in the area. If excavations are near City of Westminster water utility lines, the contractor or applicant must identify the exact subsurface location (depth) by hand excavation before using power equipment.
28. Pipelines exposed during excavation require inspection by City of Westminster Water staff.
29. Sand shall be used to surround the City of Westminster water pipelines with a minimum of 6-inch bedding and 12-inch cover. Warning tape shall be placed 12 inches above the pipe. No cement slurry is allowed within 12 inches of water pipelines and/or services.
30. Contractors must exercise due diligence to protect existing pipelines and prevent encroachments or damage. In case of pipeline damage, the City of Westminster must be notified immediately to facilitate proper repairs.
31. A three-foot clearance shall be maintained around all water mains, including water valves, fire hydrant valves, fire service valves, and water meter valves.
32. The Water Division Representative shall conduct a visual inspection of all water main valves, tees, 90-degree and 45-degree fittings, or other pipeline components.

\*\*\*End of Water Notes\*\*\*

**Standard Requirements for Disinfection of  
Water Mains**

~~CITY OF WESTMINSTER~~ STANDARD REQUIREMENTS  
FOR DISINFECTION OF NEWLY INSTALLED WATER MAINS

**PURPOSE:**

The purpose of this standard is to establish the minimum requirements for the disinfection of water mains, including the preparation of water mains, application of chlorine, and sampling and testing for the presence of coliform bacteria. The goal is to disinfect the water main(s) to eliminate coliform bacteria.

**SCOPE:**

Following the completion of hydrostatic testing, cleaning, chlorination, and flushing procedures, water samples shall be collected for bacteriological analysis. Based on the laboratory results, the City Water Quality Supervisor ~~must receive~~ (hereinafter referred to as WQS) will provide verbal approval, subsequently confirmed in writing for use, or will issue verbal disapproval, which necessitates re-chlorination of the water system.

**REQUIRED SUBMITTAL:**

Submit a written disinfection plan ~~in writing a minimum of one week before witnessing~~ with drawings for approval to the ~~disinfecting of~~ WQS at least five (5) working days prior to scheduling the ~~new water~~ disinfection of the ~~main line.~~ (s).

The plan ~~must~~ shall include the following components:

- 1. Demonstrate ~~with the plan~~ how a minimum 50 mg/L FREE chlorine residual in the new ~~pipeline (or section)~~ main will be achieved.

  - a. ~~Must see a~~ consistent 50 mg/L residual or more must be observed in the each new pipeline section's effluent water flush stream.
  - b. The chlorine dose and residual levels ~~must be witnessed~~ observed by a Westminster Water Division employee on the WQS or designee, utilizing a digital readout ~~screen device~~, such as a Hach "Drop Count Titration" test kit (CN-21P) or ~~similar device which measures an equivalent instrument capable of measuring within the range of~~ 10-200 mg/L. –A test kit that ~~matches~~ relies solely on color matching to a chart is ~~not acceptable~~ deemed unacceptable.

- 2. A ~~Disinfection plan shall include~~ drawing(s), showing:

- ~~Where the~~The source of water will be coming from to loadfor filling and flushing the new pipelinemain section, keeping in mind the minimum flushing velocity requirement of 3.0 feet/second.
- ~~Where~~The location of the backflow prevention device will be placed.
- ~~Diagram~~A detailed diagram of the piping, and length,main(s) to be disinfected, including lengths.
- ~~How the water will be~~The proposed method for super-chlorinatedchlorinating the water and the location of the proposed injection point.
- How the highly chlorinated water will be isolated from the rest of the water system.7.
- ~~How the water will be flushed from~~The procedure for flushing the new main section.
- ~~How de-chlorination will be achieved for~~The location of all discharges and methods for achieving compliance with NPDES requirements, including dechlorination.
- Sample points and number of samples to be taken, and ~~at what~~the intervals for sampling.
- ~~Which~~The name of the state-certified laboratory that will beconduct the sample testingthe samples.

~~NPDES regulations and standards must be observed. No job will start without the prior approval of the written plan from the Water Quality Supervisor.~~

### **GENERAL:**

The ~~contractor~~Contractor shall ~~supply~~provide all ~~material~~materials, labor, equipment, and ~~method~~necessarymeans required to ~~conduct tests~~perform testing and ~~provide~~to obtain certification of pipeline disinfection from a ~~state~~laboratory approved ~~laboratory~~by the state. All tests shall be ~~made~~conducted by a technician accredited by the state-approved laboratory, in the presence of the WQS.

During ~~City of Westminster's Water Quality Coordinator (or his/her designee)~~ by a state approved lab technician. ~~All portions of the testing, all pipeline sections~~ under construction shall be isolated from the ~~existing~~ public water system ~~while being tested~~. Potable water can be supplied through a temporary connection to the existing system, such as a fire hydrant, blow-off, or other means. An approved reduced-pressure principal backflow prevention assembly must be installed properly to protect the existing water supply system.

Compliance with NPDES regulations and standards is mandatory. The contractor shall implement,

inspect, and maintain an effective combination of Best Management Practices (BMPs) for erosion and sediment control, non-stormwater management, and material management throughout the project duration, including any periods of temporary work suspension.

The contractor **NOTE:**

All existing city water line valves shall be operated solely by city crews. Contractor must contact city Water Department 48 hours prior to shut down, tie-ins, etc., to schedule operating any city water line valves. Water Department supervisors' phone numbers are (714) 548-3699 or (714) 548-3697. All new piping must be isolated from the water system and a backflow device must be inserted prior to loading water into the new main.

**ABBREVIATED** is required to proactively modify Best Management Practices (BMPs) as necessary to accommodate changing weather conditions, evolving construction activities, and site-specific requirements, thereby ensuring continuous compliance.

No work shall begin without prior approval from the WQS.

#### **HYDROSTATIC TESTING:**

The main(s) shall have successfully met the hydrostatic pressure testing requirements prior to any high velocity flushing and disinfection, and shall comply with the following:

- Hydrostatic pressure testing is required on all newly installed or reintroduced water mains and connected appurtenances. Only qualified personnel shall conduct the hydrostatic pressure test to ensure safety and proper execution. The individual conducting the test shall provide accurate measurement gauges and recording devices, including the pump, pipe, connections, and any other necessary equipment. The WQS or designee shall be present during the test. After completing the hydrostatic pressure test, the Contractor shall submit a signed copy of all test results to the WQS.
- All concrete thrust blocks and anchor blocks within the tested pipe sections must reach a minimum compressive strength of 2,000 PSI before pressurization unless approved in advance by WQS. Restrained joints or other pipe-restraint methods are permitted only if approved in advance by the WQS or designee.

- The quantity of pipes to be tested at one time shall be approved by the WQS but shall not exceed 1,200 feet. Test plates, bulkheads, blow-offs, corporation stops, and other required appurtenances shall be installed at the Contractor's expense. Testing directly against a closed valve is not permitted.
- Through a temporary connection to the public water system, such as a fire hydrant, blow-off, or other means, the pipe being tested shall be carefully filled with potable water. An approved reduced-pressure principle backflow prevention assembly must be installed to protect the public water system. During the filling process, provisions must be in place to purge air from all high points and pipe ends. All visible pipe sections, fittings, and appurtenances shall be inspected for leaks.
- Once the pipe section being tested is filled with potable water and no visible leaks are observed, the pressure shall be increased to 140 psi. When the test pressure stabilizes at 140 psi, and the pressurizing equipment has been removed, the two (2)-hour test period can begin. Any pressure loss greater than 3 psi during the test period will be considered a failed result. The Contractor shall identify the points of leakage and complete the necessary repairs at no cost to the City. Once the defective elements are repaired, removed, or replaced, the test shall be repeated until the requirements are met.
- At the completion of the hydrostatic test, where feasible, all valves shall be tested for leak-proof tightness with test pressure on one side and atmospheric pressure on the other side.

**PRELIMINARY FLUSHING:**

Before chlorinating the main, it must be gradually filled with potable water. Care must be taken to remove any air that may have collected at high points and at the ends of all pipeline sections and laterals. All pipeline section ends should be equipped with a temporary blow-off and flush valve large enough to achieve a minimum flushing velocity of 3.0 ft/sec. Each pipeline section shall be flushed at this velocity to clear out any particulates that may have accumulated during construction.

**PROCEDURE ~~OF~~FOR DISINFECTION PROCESS:**

All new and reintroduced water mains, water services, attached appurtenances, and connections shall

be disinfected in accordance with AWWA Standard C651-14 for "Disinfecting water mains" as modified herein, prior to being placed in service. In case of any conflict, the requirements of this standard will prevail.(See below for more detailed information)

- ~~The Water Quality Supervisor must receive and approve a disinfection plan w/ drawings~~
- ~~Plan must demonstrate how 50 mg/L FREE chlorine residual will be achieved.~~

A drawing of the process Disinfection shall be accomplished using the continuous-feed method unless otherwise approved by the WQS. WQS shall review and approve the procedures and schedule(s) prior to initiation of work.

- ~~All pipes and appurtenances must be included~~
- 1. Keep all pipe and appurtenances clean and, dry, and free of contamination. If any foreign substances have entered during storage, they should be cleaned and swabbed with a solution containing at least 6% Sodium Hypochlorite, then thoroughly dried.
  - ~~If anything did enter the pipe while in storage, clean and swab pipe with chlorine bleach, let dry~~
  - ~~Introduce enough chlorine to achieve a FREE chlorine dose of 50 mg/L to 100 mg/L~~
- 2. Only Water Division employees will very slowly load Using the continuous feed method, chlorine shall be injected into the water entering the new mains at a minimum dose of 50 mg/L (100 mg/L maximum). Chlorine application shall not cease until the entire main is filled with chlorinated water. To ensure the proper dose is achieved, free chlorine concentration shall be measured at regular intervals (at least one every 200 feet, plus one at the end of each pipeline section or branch), using an approved chlorine test kit.
  - ~~All valves and other appurtenances within the new main with distribution system water~~
- 3. Operate any valves or other appurtenances in the new section of main several section shall be operated multiple times by the contractor, after the pipe is loaded has been filled with the highly chlorinated water to expose appurtenances to chlorination, to ensure adequate disinfection.
  - ~~Let stand for 24 hrs.~~
- 4. The chlorinated water shall remain undisturbed in the new main for a minimum of 24 hours. Warning signs/tags must be posted at each outlet.
- 5. At the end of this 24-hour period, the free chlorine residual (must be a minimum of 50% of shall be measured at the same locations used to verify the initial dose,; it must be at least 50% of the initial dose, but in no case less than 25 mg/L; if. If this standard is not start over)met, the process shall be repeated.

- ~~Flush the main to achieve a system residual (about 0.6 mg/L Free Cl<sub>2</sub>; 2.0 mg/L Total Cl<sub>2</sub>)~~
- ~~Let stand for 24 hrs.~~
- 6. Contractor's lab ~~The highly chlorinated water shall be flushed from the main at its extremities and at all outlets until the chlorine residual matches that of the public water system.~~
- 7. The system shall remain undisturbed for an additional 24 hours. After 24 hours, free chlorine residuals shall be measured again at each sample point to verify that they have not increased or decreased significantly.
- 8. The contractor shall have a state-certified laboratory technician ~~draws a minimum of 2 x 100 mL samples (with perform the bacteriological tests and measure free and total chlorine residuals) in~~ for each sample. Samples shall be taken under the direction of WQS, with at least one set of samples collected from each end of pipe section, as well as one additional set of samples for every 200 feet of pipe installed.
- 9. From each sampling location, at least two 100 mL samples, containing both free and total chlorine residuals, must be collected. Each sample shall be collected by a contractor's technician 15 minutes apart, in the presence of the WQS or designee, and sent to a state-approved laboratory. Consult the Water Quality Coordinator (or his/her designee) and takes Supervisor to state approved lab (extra determine if additional samples are necessary for long runs of pipe).
- 10. Laboratory ~~The laboratory~~ must use perform the Chromogenic Substrate Coliform Test, using APHA Standard Methods for the Examination of Water and Wastewater, 21<sup>st</sup> Ed., 2005 24th Edition, Method 9223 B, Colilert ~~Presence/~~ to detect the presence or absence per 100 mL, where "Absence per 100ml; where "Absence" equals" indicates "None Detected" detected," and use SM 9215B to determine the Heterotrophic Plate Counts (HPC).
- 11. Results from lab must be Coliform ~~Laboratory results must confirm no presence of coliform bacteria and E-Coli absent. coli, and the Heterotrophic Plate Count must be less than~~ below 200.
  - ~~Submit a clear, legible copy~~ Prior to acceptance of the new water mains, Contractor shall submit state-certified lab bacteriological test results to the City of Westminster's Water Quality Coordinator and followed up by a certified (seal of Lab) hard copy to same.
- 12. Have Water Quality Coordinator approve WQS for final approval. Approval from the WQS must be obtained prior to connecting to city's ~~any new water mains to the existing public water system.~~
  - ~~City crews open~~ personnel will operate the valves to connect the new pipe section of pipe to the distribution system.

The new pipe, fittings, and valve(s) required for the connection must be sprayed or swabbed with a minimum six (6) percent Sodium Hypochlorite solution for disinfection, in the presence of the WQS or designee, just

13. All new water mains shall be disinfected before they are placed into service. All water mains taken out of service for any reason shall be flushed and disinfected before they are returned to service being installed. Sanitary construction practices must be followed during the installation of the final connections.

### **KEEP PIPES CLEAN AND DRY:**

~~Precautions shall be taken to protect the~~

#### **NOTES:**

All existing city water line valves shall be operated solely by city personnel. Contractor must contact the City Water Division at least 72 hours prior to any shutdowns, tie-ins, or related activities to coordinate the operation of city water line valves. Water Department supervisors' phone numbers are (714) 548-3694 or (714) 548-3696.

The interiors of pipes, fittings, and valves appurtenances shall be protected against contamination. Pipe delivered for installation to Pipelines used within the water system shall be delivered so as handled to minimize the entrance entry of foreign material. materials, including dirt, rodents, and other contaminants.

All pipe openings in the pipeline shall be closed sealed with water-tight plugs at the close of the work day or at any other time, following daily operations, whenever work in that section of pipeline ceases, or when work to that section of pipeline stops, or when it will be it is left unattended for any length of time.

If water accumulates in the trench, the plugs shall remain in place until the trench is dry. has fully dried. Sections of pipe pipelines not being used in a day's work shall have the ends covered to guard against contamination of any kind.

### SEALING MATERIALS:

No contaminated material or any material capable of supporting prolific microbial growth ~~of microorganisms~~ shall be used for sealing joints. Sealing ~~material~~materials or gaskets shall be handled ~~in a manner that avoids~~to prevent contamination. The lubricant used ~~in~~during the installation of sealing gaskets shall be suitable for ~~use in~~ potable water, meet the requirements of NSF/ANSI 61, and ~~NSF approved~~shall not contribute to odors.

### CLEANING AND SWABBING:

If dirt or other debris enters the pipe, it shall be removed, and the interior pipe surface shall be swabbed clean with a minimum of a six (6) percent Sodium Hypochlorite disinfecting solution.

### FLOODING BY STORM OR ACCIDENT DURING CONSTRUCTION:

If the main pipeline is flooded during construction, it shall be cleared of the ~~flood water~~floodwater and flushed with potable water until it is clean. The section exposed to the ~~flood water~~floodwater shall be filled with potable water, which shall be chlorinated sufficiently so that, at the end of a 24-~~hr.~~hour holding period, it will have a free chlorine residual of not less than 25 mg/L. The chlorinated water may then be drained or flushed from the main. After construction is completed, the main shall be disinfected using the *continuous-feed method*.

### DISINFECTION:

~~Prior to disinfection the new water main shall be flushed with system water to remove any residual debris and eliminate any air pockets. All water mains, water services, attached appurtenances, and connections shall be disinfected in accordance with AWWA Standard C651-99 for "Disinfecting water mains" as modified herein.~~ \*\*\*End of Standard Requirements for

#### Disinfection of Water Mains\*\*\*

~~shall insure that all pipes, fittings, and appurtenances are kept free from dirt, rodents, foreign matter, etc., at all times.~~

~~the disinfection process all valves shall be operated, and the chlorine solution shall be drawn through all laterals and appurtenances using every precaution to not contaminate the public water system with the highly chlorinated water.~~

~~Disinfection shall be accomplished by using the "chlorine gas—continuous feed" method (unless otherwise approved by the Water Quality Coordinator).~~

## **“CHLORINE GAS – CONTINUOUS FEED” METHOD**

Using the continuous feed method, gaseous chlorine will be injected into the water mains at a minimum *dose* of 50 mg/L (100 mg/L maximum). A chlorine residual test will be taken at appropriate places (at a minimum of one per every 200 feet, plus one at each end of all pipe) to verify residual levels throughout the new pipeline section.

The chlorinated water shall remain in the new water mains for 24 hours. After 24 hours, chlorine residual levels will again be measured at various places in the newly installed water main. A minimum 50% free chlorine *residual* of 25 mg/L or greater must remain.

## **FLUSHING AND BACTERIOLOGICAL TESTING:**

Following the chlorination period of 24 hours (and minimum 50% of chlorine residual), the water shall be flushed from the main at its extremities and at all outlets until the chlorine residual of the water being flushed equals that of the public water system (which is typically 0.6 mg/L *Free* chlorine or between 0.6 to 2.0 mg/L “*Total*” chlorine). The chlorine must be neutralized.

Fresh water will be loaded into the pipe and shall remain in the new water mains for 24 hours.

The contractor shall have a state certified laboratory technician perform the bacteriological tests and take free and total chlorine residuals of each. Samples shall be taken at the direction of the City of Westminster’s Water Quality Coordinator with at least one sample taken from each dead end main section. **For every 200 foot of pipe length being disinfected, one additional sample and set of chlorine residuals must be taken in addition to each of the ends.** Samples shall be taken 24 or more hours after final flushing. All samples must show absence of coliform and E-Coli organisms, and each Heterotrophic Plate Count (HPC) shall be less than 200.

## **FINAL APPROVAL AFTER BACTERIOLOGICAL TESTING:**

Prior to acceptance of the new water mains, Contractor shall submit state *certified* bacteriological tests from the laboratory to City of Westminster’s Water Quality Coordinator at (714) 548-3699, for review and final approval prior to any new water mains being placed into service.

## **RECORD OF COMPLIANCE:**

Bacteriological samples shall be taken after repairs / installations are completed (but prior to connecting to city water system) to provide a record for determining the procedure’s effectiveness. The record of compliance shall be the bacteriological test results certifying the water sampled from the water main to be free of Coliform and E-Coli bacteria contamination, and heterotrophic plate count must be less than 200.

## **DEFINITIONS:**

### **Free Chlorine**

Free available residual chlorine is free in the sense that it has not reacted with anything and is available in that it can and will react if need be. It has not yet combined with any other chemicals in drinking water

such as ammonia to form ~~*Total Chlorine*~~. ~~*Free chlorine*~~ is faster reacting disinfectant than other forms of chlorine.

### **Total Chlorine**

~~*Total or Combined chlorine*~~ is ~~*Free chlorine*~~ which has combined with natural or added ammonia or other chemicals in drinking water. It still has disinfecting abilities, however it is slower reacting than ~~*Free Chlorine*~~.

## STANDARD REQUIREMENTS FOR DISINFECTION OF WATER MAINS

### **PURPOSE:**

The purpose of this standard is to establish the minimum requirements for the disinfection of water mains, including the preparation of water mains, application of chlorine, and sampling and testing for the presence of coliform bacteria. The goal is to disinfect the water main(s) to eliminate coliform bacteria.

### **SCOPE:**

Following the completion of hydrostatic testing, cleaning, chlorination, and flushing procedures, water samples shall be collected for bacteriological analysis. Based on the laboratory results, the City Water Quality Supervisor (hereinafter referred to as WQS) will provide verbal approval, subsequently confirmed in writing for use, or will issue verbal disapproval, which necessitates re-chlorination of the water system.

### **REQUIRED SUBMITTAL:**

Submit a written disinfection plan with drawings for approval to the WQS at least five (5) working days prior to scheduling the disinfection of the main(s).

The plan shall include the following components:

1. Demonstrate how a minimum 50 mg/L FREE chlorine residual in the new main will be achieved.
  - a. A consistent 50 mg/L residual or more must be observed in each new pipeline section's effluent water flush stream.
  - b. The chlorine dose and residual levels must be observed by the WQS or designee, utilizing a digital readout device, such as a Hach "Drop Count Titration" test kit (CN-21P) or an equivalent instrument capable of measuring within the range of 10-200 mg/L. A test kit that relies solely on color matching to a chart is deemed unacceptable.
2. Disinfection plan shall include drawing(s), showing:
  - o The source of water for filling and flushing the new main section, keeping in mind the minimum flushing velocity requirement of 3.0 feet/second.
  - o The location of the backflow prevention device.
  - o A detailed diagram of the main(s) to be disinfected, including lengths.

- The proposed method for super-chlorinating the water and the location of the proposed injection point.
- How the highly chlorinated water will be isolated from the rest of the water system.
- The procedure for flushing the new main section.
- The location of all discharges and methods for achieving compliance with NPDES requirements, including dechlorination.
- Sample points and number of samples to be taken, and the intervals for sampling.
- The name of the state-certified laboratory that will conduct the sample testing.

**GENERAL:**

The Contractor shall provide all materials, labor, equipment, and means required to perform testing and to obtain certification of pipeline disinfection from a laboratory approved by the state. All tests shall be conducted by a technician accredited by the state-approved laboratory, in the presence of the WQS.

During testing, all pipeline sections under construction shall be isolated from the public water system. Potable water can be supplied through a temporary connection to the existing system, such as a fire hydrant, blow-off, or other means. An approved reduced-pressure principal backflow prevention assembly must be installed properly to protect the existing water supply system.

Compliance with NPDES regulations and standards is mandatory. The contractor shall implement, inspect, and maintain an effective combination of Best Management Practices (BMPs) for erosion and sediment control, non-stormwater management, and material management throughout the project duration, including any periods of temporary work suspension.

The contractor is required to proactively modify Best Management Practices (BMPs) as necessary to accommodate changing weather conditions, evolving construction activities, and site-specific requirements, thereby ensuring continuous compliance.

No work shall begin without prior approval from the WQS.

**HYDROSTATIC TESTING:**

The main(s) shall have successfully met the hydrostatic pressure testing requirements prior to any high velocity flushing and disinfection, and shall comply with the following:

- Hydrostatic pressure testing is required on all newly installed or reintroduced water mains and connected appurtenances. Only qualified personnel shall conduct the hydrostatic pressure test to ensure safety and proper execution. The individual conducting the test shall provide accurate measurement gauges and recording devices, including the pump, pipe, connections, and any other necessary equipment. The WQS or designee shall be present during the test. After completing the hydrostatic pressure test, the Contractor shall submit a signed copy of all test results to the WQS.
- All concrete thrust blocks and anchor blocks within the tested pipe sections must reach a minimum compressive strength of 2,000 PSI before pressurization unless approved in advance by WQS. Restrained joints or other pipe-restraint methods are permitted only if approved in advance by the WQS or designee.
- The quantity of pipes to be tested at one time shall be approved by the WQS but shall not exceed 1,200 feet. Test plates, bulkheads, blow-offs, corporation stops, and other required appurtenances shall be installed at the Contractor's expense. Testing directly against a closed valve is not permitted.
- Through a temporary connection to the public water system, such as a fire hydrant, blow-off, or other means, the pipe being tested shall be carefully filled with potable water. An approved reduced-pressure principle backflow prevention assembly must be installed to protect the public water system. During the filling process, provisions must be in place to purge air from all high points and pipe ends. All visible pipe sections, fittings, and appurtenances shall be inspected for leaks.
- Once the pipe section being tested is filled with potable water and no visible leaks are observed, the pressure shall be increased to 140 psi. When the test pressure stabilizes at 140 psi, and the pressurizing equipment has been removed, the two (2)-hour test period can begin. Any pressure loss greater than 3 psi during the test period will be considered a failed result. The Contractor shall identify the points of leakage and complete the necessary repairs at no cost to the City. Once the defective elements are repaired, removed, or replaced, the test shall be repeated until the requirements are met.

- At the completion of the hydrostatic test, where feasible, all valves shall be tested for leak-proof tightness with test pressure on one side and atmospheric pressure on the other side.

**PRELIMINARY FLUSHING:**

Before chlorinating the main, it must be gradually filled with potable water. Care must be taken to remove any air that may have collected at high points and at the ends of all pipeline sections and laterals. All pipeline section ends should be equipped with a temporary blow-off and flush valve large enough to achieve a minimum flushing velocity of 3.0 ft/sec. Each pipeline section shall be flushed at this velocity to clear out any particulates that may have accumulated during construction.

**PROCEDURE FOR DISINFECTION PROCESS:**

All new and reintroduced water mains, water services, attached appurtenances, and connections shall be disinfected in accordance with AWWA Standard C651-14 for "Disinfecting water mains" as modified herein, prior to being placed in service. In case of any conflict, the requirements of this standard will prevail. Disinfection shall be accomplished using the continuous-feed method unless otherwise approved by the WQS. WQS shall review and approve the procedures and schedule(s) prior to initiation of work.

1. All pipes and appurtenances must be clean, dry, and free of contamination. If any foreign substances have entered during storage, they should be cleaned and swabbed with a solution containing at least 6% Sodium Hypochlorite, then thoroughly dried.
2. Using the continuous feed method, chlorine shall be injected into the water entering the new mains at a minimum *dose* of 50 mg/L (100 mg/L maximum). Chlorine application shall not cease until the entire main is filled with chlorinated water. To ensure the proper dose is achieved, free chlorine concentration shall be measured at regular intervals (at least one every 200 feet, plus one at the end of each pipeline section or branch), using an approved chlorine test kit.
3. All valves and other appurtenances within the new section shall be operated multiple times by the contractor, after the pipe has been filled with highly chlorinated water, to ensure adequate disinfection.
4. The chlorinated water shall remain undisturbed in the new main for a minimum of 24 hours. Warning signs/tags must be posted at each outlet.
5. At the end of this 24-hour period, the free chlorine residual shall be measured at the same locations used to verify the initial dose; it must be at least 50% of the initial dose, but in no case less than 25

mg/L. If this standard is not met, the process shall be repeated.

6. The highly chlorinated water shall be flushed from the main at its extremities and at all outlets until the chlorine residual matches that of the public water system.
7. The system shall remain undisturbed for an additional 24 hours. After 24 hours, free chlorine residuals shall be measured again at each sample point to verify that they have not increased or decreased significantly.
8. The contractor shall have a state-certified laboratory technician perform the bacteriological tests and measure free and total chlorine residuals for each sample. Samples shall be taken under the direction of WQS, with at least one set of samples collected from each end of pipe section, as well as one additional set of samples for every 200 feet of pipe installed.
9. From each sampling location, at least two 100 mL samples, containing both free and total chlorine residuals, must be collected. Each sample shall be collected by a contractor's technician 15 minutes apart, in the presence of the WQS or designee, and sent to a state-approved laboratory. Consult the Water Quality Supervisor to determine if additional samples are necessary.
10. The laboratory must perform the Chromogenic Substrate Coliform Test, using APHA Standard Methods for the Examination of Water and Wastewater, 24th Edition, Method 9223 B, Colilert to detect the presence or absence per 100 mL, where "Absence" indicates "None detected," and SM 9215B to determine the Heterotrophic Plate Counts (HPC).
11. Laboratory results must confirm no presence of coliform bacteria and E. coli, and the Heterotrophic Plate Count must be below 200.
12. Prior to acceptance of the new water mains, Contractor shall submit *state-certified* bacteriological test results to WQS for final approval. Approval from the WQS must be obtained prior to connecting any new water mains to the existing public water system.
13. City personnel will operate the valves to connect the new pipe section to the distribution system. The new pipe, fittings, and valve(s) required for the connection must be sprayed or swabbed with a minimum six (6) percent Sodium Hypochlorite solution for disinfection, in the presence of the WQS or designee, just before being installed. Sanitary construction practices must be followed during the installation of the final connections.

**NOTES:**

All existing city water line valves shall be operated solely by city personnel. Contractor must contact the City Water Division at least 72 hours prior to any shutdowns, tie-ins, or related activities to coordinate the operation of city water line valves. Water Department supervisors' phone numbers are (714) 548-3694 or (714) 548-3696.

The interiors of pipes, fittings, and appurtenances shall be protected against contamination. Pipelines used within the water system shall be handled to minimize the entry of foreign materials, including dirt, rodents, and other contaminants.

All pipe openings shall be sealed with water-tight plugs, following daily operations, whenever work in that section of pipeline ceases, or when it is left unattended for **any** length of time.

If water accumulates in the trench, the plugs shall remain in place until the trench has fully dried. Sections of pipelines not being used in a day's work shall have the ends covered to guard against contamination of any kind.

No contaminated material or any material capable of supporting prolific microbial growth shall be used for sealing joints. Sealing materials or gaskets shall be handled to prevent contamination. The lubricant used during the installation of sealing gaskets shall be suitable for potable water, meet the requirements of NSF/ANSI 61, and shall not contribute to odors.

If dirt or other debris enters the pipe, it shall be removed, and the interior pipe surface shall be swabbed clean with a minimum of a six (6) percent Sodium Hypochlorite disinfecting solution.

If the pipeline is flooded during construction, it shall be cleared of the floodwater and flushed with potable water until it is clean. The section exposed to the floodwater shall be filled with potable water, which shall be chlorinated sufficiently so that, at the end of a 24-hour holding period, it will have a free chlorine residual of not less than 25 mg/L. The chlorinated water may then be drained or flushed from the main. After construction is completed, the main shall be disinfected using the ***continuous-feed method***.

\*\*\*End of Standard Requirements for Disinfection of Water Mains\*\*\*

**Street Standard Plan 208**  
**– Residential Driveway Approach**

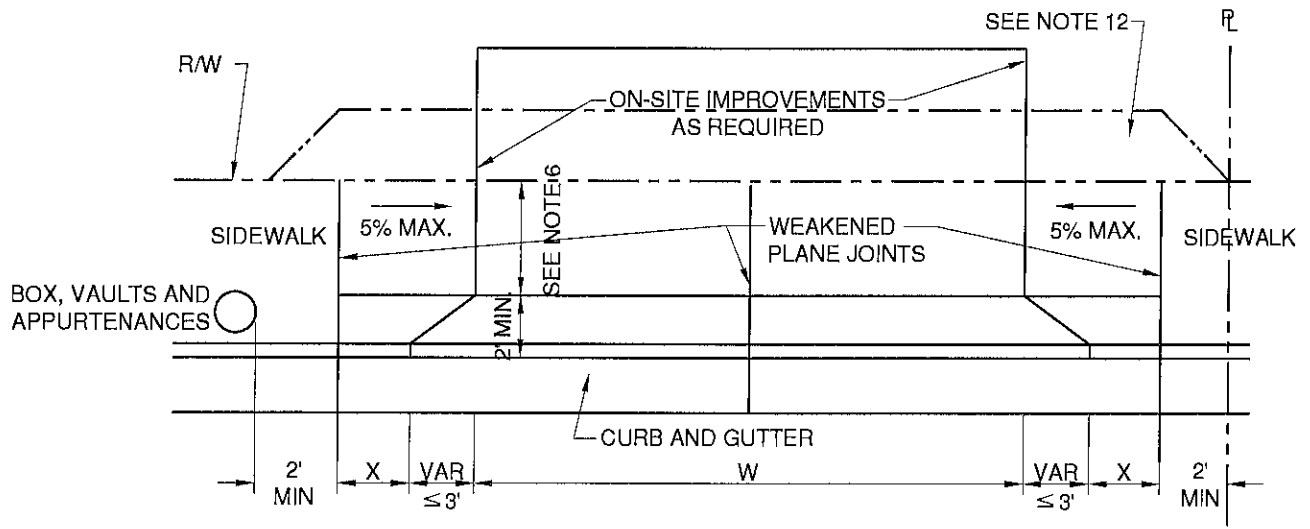

PLAN

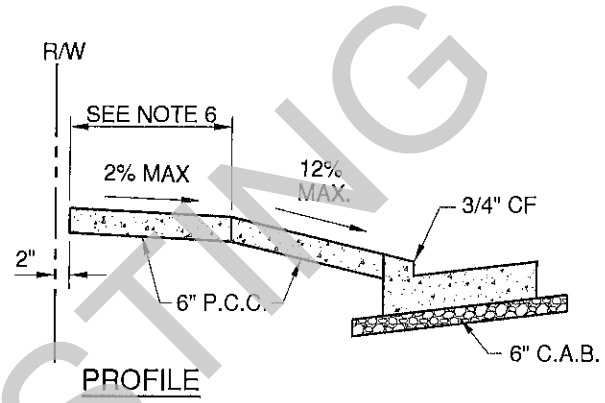

PROFILE

NOTES:

1. CONCRETE SHALL BE 520-C-2500.
2. DRIVEWAY APPROACH SHALL BE A MINIMUM OF 2' FROM CURB RETURN.
3. CURB FACE ≤ 6"; X = 3' / CURB FACE > 6"; X = 4'.
4. THERE SHALL BE A MINIMUM OF 22' OF FULL HEIGHT CURB BETWEEN APPROACHES ON SAME PROPERTY WITH THE APPROVAL OF THE CITY ENGINEER. ANY APPROVED SECONDARY DRIVEWAY APPROACH SHALL BE LIMITED TO 12' MAXIMUM IN WIDTH.
5. W SHALL BE A MINIMUM OF 12'. FOR STREET FACING GARAGE, MAXIMUM W SHALL BE 12' FOR PROPERTY WITH 1 CAR GARAGE, 18' FOR 2 CAR GARAGE, 26' FOR 3 (OR MORE) CAR GARAGE. FOR NON-STREET FACING GARAGE, MAXIMUM W SHALL BE 16'. PROPERTY WITH APPROVED ADDITIONAL DRIVEWAY WIDTH FOR ADU, ADDITIONAL 5' MAY BE REQUESTED TO THE MAXIMUM W.
6. MINIMUM WIDTH OF CLEAR PASSAGE SHALL BE 4'. WHERE RIGHT OF WAY, NATURAL BARRIERS CREATE UNREASONABLE HARDSHIP, THE CLEAR WIDTH MAY BE REDUCED TO 3'.
7. THERE SHALL BE A MINIMUM OF 2' OF FULL HEIGHT CURB FROM PROPERTY LINE.
8. HORIZONTAL CURB CUTS ARE ALLOWED IF THE EXISTING CURB AND GUTTER ARE IN GOOD SHAPE IN THE OPINION OF THE CITY ENGINEER.
9. MAXIMUM SLOPE FOR THE DRIVEWAY APPROACH SHALL BE 12%, STEEPER SLOPE SHALL REQUIRE PRIOR APPROVAL OF CITY ENGINEER.
10. EXISTING AC SHALL BE REMOVED BY SAWCUTTING AT A MINIMUM DISTANCE OF TWO FEET FROM LIP OF GUTTER.
11. MINIMUM COMPACTION FOR SOIL UNDERNEATH DRIVEWAY APPROACH SHALL BE 90%.
12. IF SIDEWALK WILL BE LOCATED OUTSIDE OF THE PUBLIC RIGHT OF WAY, A SIDEWALK EASEMENT SHALL BE DEDICATED TO THE CITY OF WESTMINSTER.

APPROVED:

*[Signature]*

P.W. DIRECTOR / CITY ENGINEER

REVISED DATE: 9/27/21



City of Westminster  
DEPARTMENT OF PUBLIC WORKS

RESIDENTIAL  
DRIVEWAY APPROACH

STANDARD NUMBER

208

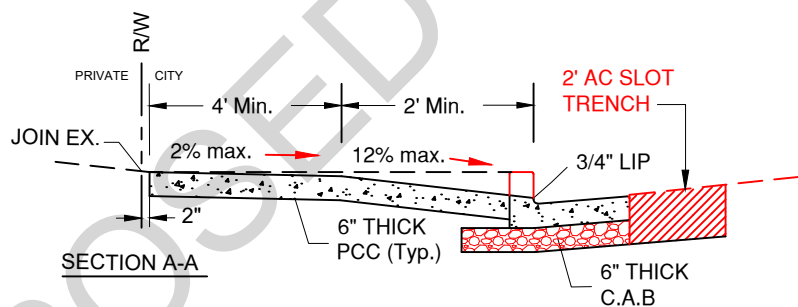
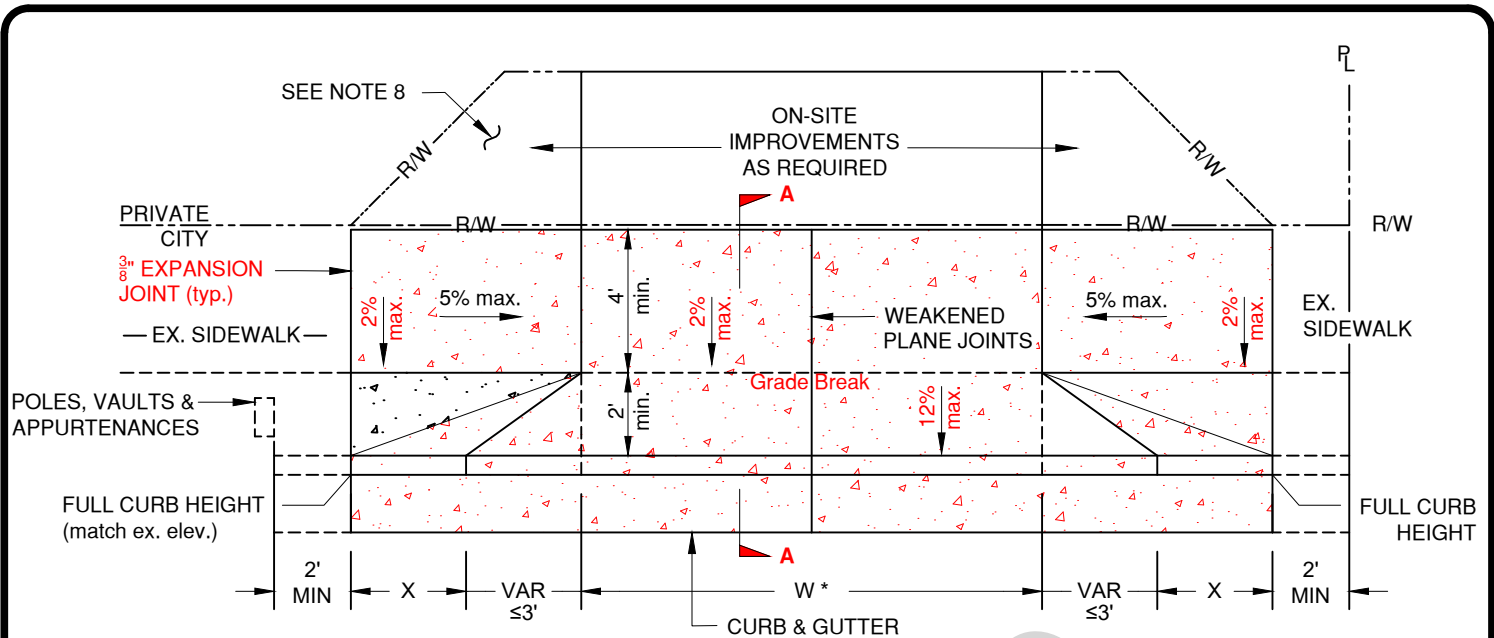

**NOTES:**

1. CONCRETE STRENGTH AND CORRESPONDING CONCRETE CLASS SHALL CONFORM TO SECTION 201-1, PORTLAND CEMENT CONCRETE, OF THE LATEST EDITION OF THE "GREENBOOK". CEMENT SHALL BE TYPE II OR TYPE V.
2. THE DRIVEWAY APPROACH SHALL BE CONSTRUCTED A MINIMUM OF TWO (2) FEET FROM THE CURB RETURN.
3. WHERE THE CURB HEIGHT IS SIX (6) INCHES OR LESS, DIMENSION "X" SHALL BE THREE (3) FEET. WHERE THE CURB HEIGHT EXCEEDS SIX (6) INCHES, DIMENSION "X" SHALL BE FOUR (4) FEET.
4. AT THE DISCRETION OF THE CITY ENGINEER, ONE ADDITIONAL DRIVEWAY APPROACH SERVING THE SAME PARCEL MAY BE PERMITTED UPON DETERMINATION THAT THE ADDITIONAL ACCESS IS NECESSARY AND CAN BE ACCOMMODATED WITHOUT CREATING UNSAFE CONDITIONS OR ADVERSE IMPACTS. WHERE APPROVED, A MINIMUM OF 22 FEET OF CONTINUOUS, FULL-HEIGHT CURB MUST BE MAINTAINED BETWEEN DRIVEWAY APPROACHES. THE PERMITTED WIDTH (W), WHETHER MINIMUM OR MAXIMUM, MUST ADHERE TO THE CORRESPONDING VALUES IN THE TABLE BELOW.

	STREET FACING GARAGE			NON- STREET FACING GARAGE		ADU/JADU/ SB9 UNIT	SITE ACCESS
	1 CAR	2 CAR	3+ CAR	SINGLE FAMILY	MULTI-FAMILY		
MIN.	12'	16'	22'	12'	18'	12'	12'
MAX.	12' *	18' *	26' *	16' *	25'	16'	12'

\* AN INCREASE OF UP TO (5) FIVE FEET IN THE WIDTH OF THE PRIMARY DRIVEWAY APPROACH IS PERMITTED UPON THE APPROVAL OF CITY ENGINEER FOR PARCELS THAT HAVE AN APPROVED ADU OR JADU, PROVIDED THAT NO SECONDARY DRIVEWAY APPROACH HAS BEEN APPROVED FOR THE LOT.

5. HORIZONTAL CURB CUTS SHALL BE PERMITTED ONLY WITH PRIOR WRITTEN APPROVAL FROM THE CITY ENGINEER.
6. THE EXISTING ASPHALT CONCRETE PAVEMENT SHALL BE REMOVED BY SAWCUTTING AT A MINIMUM DISTANCE OF TWO (2) FEET FROM THE LIP OF GUTTER.
7. THE SUBGRADE BENEATH THE DRIVEWAY APPROACH SHALL BE COMPACTED TO A MINIMUM OF 90% RELATIVE COMPACTION.
8. WHERE THE SIDEWALK IS LOCATED OUTSIDE THE PUBLIC RIGHT-OF-WAY, AN EASEMENT SHALL BE DEDICATED TO THE CITY.
9. VISIBILITY REQUIREMENTS SHALL COMPLY WITH WESTMINSTER MUNICIPAL CODE (WMC) SECTION 17.320.030(B)(3).

APPROVED BY:

VINNY T. HOANG  
CITY ENGINEER

ADOPTED DATE: MAY 13, 2026



**City of Westminster**  
DEPARTMENT OF PUBLIC WORKS

**RESIDENTIAL  
DRIVEWAY APPROACH**

STANDARD PLAN NO.

**208**

**Water Standard Plan 401-A**  
**– Meter, Water Main Connection Detail**  
**(1" Service)**

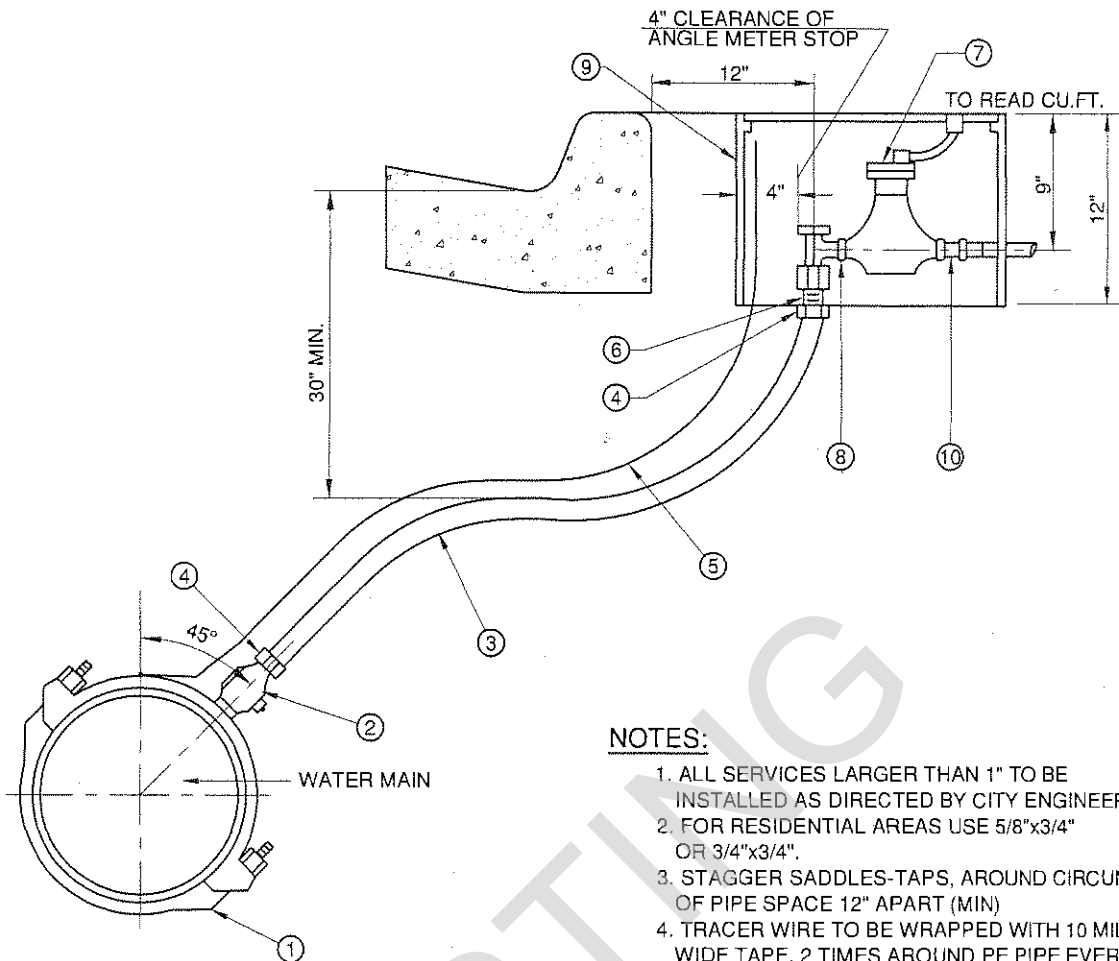

**NOTES:**

1. ALL SERVICES LARGER THAN 1" TO BE INSTALLED AS DIRECTED BY CITY ENGINEER
2. FOR RESIDENTIAL AREAS USE 5/8"x3/4" OR 3/4"x3/4".
3. STAGGER SADDLES-TAPS, AROUND CIRCUMFERENCE OF PIPE SPACE 12" APART (MIN)
4. TRACER WIRE TO BE WRAPPED WITH 10 MIL-2" WIDE TAPE, 2 TIMES AROUND PE PIPE EVERY 24", AND ACCESSIBLE INSIDE METER BOX

**MATERIALS LIST**

ITEM	DESCRIPTION
①	P.V.C. PIPE SADDLE SHALL BE FORD 202 BS BRONZE BODY/STAINLESS STEEL STRAP DOUBLE BAND OR APPROVED EQUAL. A.C. PIPE SADDLE SHALL BE FORD 202 B IP4 DOUBLE STRAP BRONZE OR APPROVED EQUAL.
②	1" CORPORATION STOP FORD F700-4 M.I.P. OR APPROVED EQUAL.
③	DRISCO PIPE 1" IPS 200 PSI PE 3408 OR APPROVED EQUAL.
④	FORD PACK JOINT COUPLING FOR PE PIPE C06-44 OR APPROVED EQUAL. ADD FORD COPPER RING SLC-4 OR APPROVED EQUAL.
⑤	PLASTIC COATED 14 GAUGE COPPER TRACER WIRE FOR FUTURE DETECTION. FULL LENGTH OF PE PIPE.
⑥	1" FORD ANGLE METER STOP #KV23444W OR APPROVED EQUAL, LOCKABLE.
⑦	WATER METERS TO SENSUS 3/4"x1" SRII TRPL
⑧	FOR METERS 5/8"x3/4" OR 3/4"x3/4" USE 3/4"x1" METER ADAPTER FORD CAT #A 34.
⑨	METER BOX TO BE J&R W4 1/2 POLYMER BOX. COVER SHALL BE J&R W4 1/2 POLYMER LID FITTED FOR TOUCH READ OR APPROVED EQUAL SET TO FINISH GRADE BY CONTRACTOR.
⑩	METER COUPLING TO BE JAMES JONES J-130 PLUS INSERT WITH FEMALE ADAPTOR

APPROVED:

*William Yousse*  
P.W. DIRECTOR / CITY ENGINEER



**City of Westminster**

DEPARTMENT OF PUBLIC WORKS

METER, WATER MAIN  
CONNECTION DETAIL  
(1" SERVICE)

STANDARD NUMBER

401

REVISED DATE: 5/15/08

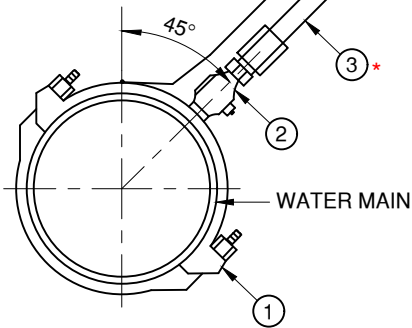
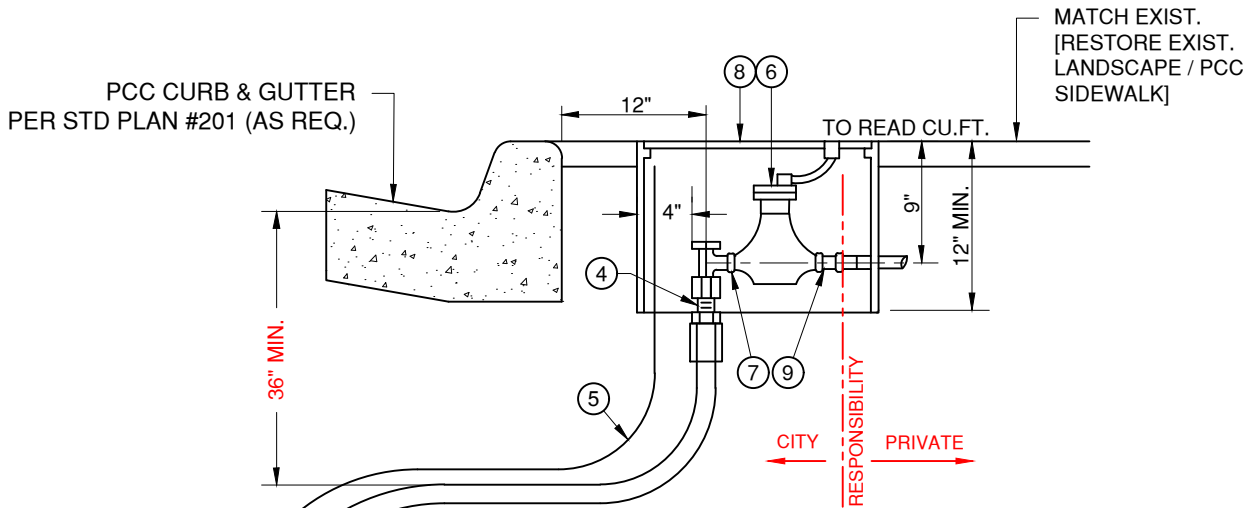

**NOTES:**

1. RESIDENTIAL AREAS SHALL USE EITHER A 3/4" x 3/4" METER OR A 1" METER, SUBJECT TO APPROVAL BY THE WATER DIVISION.
2. TAPPING SADDLES SHALL BE STAGGERED AROUND THE CIRCUMFERENCE OF THE PIPE AND SPACED A MINIMUM OF 24 INCHES APART.
3. TRACER WIRE SHALL BE WRAPPED WITH TEN (10) MIL BY TWO (2) INCH TAPE A MINIMUM OF TWO (2) TIMES AROUND PE PIPE AT 24-INCH INTERVALS. TRACER WIRE SHALL BE ACCESSIBLE WITHIN THE METER BOX.
4. METER BOX LOCATION SHALL BE SUBJECT TO APPROVAL BY THE WATER DIVISION. METER BOXES SHALL BE INSTALLED CLEAR OF DRIVEWAY APPROACHES AND ADA ACCESSIBLE PATHS OF TRAVEL.
5. ALL HOT TAPPING METHODS SHALL REQUIRE PRIOR APPROVAL BY THE WATER DIVISION.
6. ALL DISTURBED LANDSCAPE FEATURES AND CONCRETE SIDEWALK SHALL BE RESTORED TO PRECONSTRUCTION CONDITION OR BETTER.
7. "NO-OX-ID A SPECIAL" GREASE SHALL BE APPLIED WHERE APPLICABLE AND AS DIRECTED BY THE ENGINEER OR DESIGNEE.
8. \* WHEN APPROVED BY THE WATER DIVISION, COPPER PIPE SHALL BE WRAPPED WITH SIX (6) MIL BLUE POLYWRAP-C SLEEVE. POLYETHYLENE TAPE SHALL BE USED TO FULLY SEAL BOTH ENDS OF THE PIPE SLEEVE.
9. COUPLINGS SHALL NOT BE USED UNLESS SPECIFICALLY APPROVED BY THE WATER DIVISION.

NO.	DESCRIPTION
①	<u>P.V.C. PIPE SADDLE</u> : SHALL BE FORD 202 BS BRONZE BODY/STAINLESS STEEL STRAP DOUBLE BAND OR APPROVED EQUAL. <u>A.C. PIPE SADDLE</u> : SHALL BE FORD 202 B IP4 DOUBLE STRAP BRONZE OR APPROVED EQUAL.
②	1" CORPORATION STOP FORD FB700-4-NL WITH FORD PACK JOINT COUPLING C04-44CTS OR APPROVED EQUAL. ADD FORD COPPER RING SL C-4.
③	REHAU MUNICIPEX SDR9 (CTS) PART NO. 261076 OR APPROVED EQUAL, WITH FORD STAINLESS STEEL INSERT 52 ON BOTH ENDS.
④	1" FORD ANGLE METER STOP BA-43-444W-NL OR APPROVED EQUAL, LOCKABLE.
⑤	PLASTIC COATED 14 GAUGE COPPER TRACER WIRE FOR FUTURE DETECTION. FULL LENGTH OF P.E. PIPE.
⑥	<u>METER</u> : IPERL METAL 100CF TR/PL HOUSING WITH 2 WIRE IPERL PIGTAIL.
⑦	FOR METERS 3/4"x3/4" USE 3/4"x1" METER ADAPTER FORD CAT #A 34.
⑧	<u>SOFTSCAPE</u> : METER BOX IS TO BE ARMORCAST ROTOCAST BOX #AN1118B102 WITH #AG1118WP0S050H02 FOR THE COVER. <u>HARDSCAPE</u> : METER BOX IS TO BE ARMORCAST 20K POLYMER CONCRETE #AG1118B105 WITH ARMORCAST 20K #AG1118WW0S050H02 FOR THE COVER.
⑨	METER COUPLING - FORD C31-44-NL (1" METER), FORD C31-24-NL (3/4" METER), TO BE INSERTED WITH FEMALE ADAPTOR.

APPROVED BY:

VINNY T. HOANG  
CITY ENGINEER

ADOPTED DATE: MAY 13, 2026



**City of Westminster**  
DEPARTMENT OF PUBLIC WORKS

**METER, WATER MAIN  
CONNECTION DETAIL**  
(1" SERVICE)

STANDARD PLAN NO.

**401-A**

**Water Standard Plan 401-B**

**– 1” Service Line w/ Fire Connection Detail  
(Residential Application)**

**NOTES:**

1. FOR 3/4" x 3/4" METERS, PROVIDE TWO (2) 3/4" x 1" FORD NO. A34 METER ADAPTERS.
2. TAPPING SADDLES SHALL BE STAGGERED AROUND THE CIRCUMFERENCE OF THE PIPE AND SPACED A MINIMUM OF 24 INCHES APART.
3. TRACER WIRE SHALL BE WRAPPED WITH 10 MIL BY TWO (2) INCH TAPE A MINIMUM OF TWO (2) TIMES AROUND PE PIPE AT 24-INCH INTERVALS. TRACER WIRE SHALL BE ACCESSIBLE WITHIN THE METER BOX.
4. METER BOX LOCATION SHALL BE SUBJECT TO APPROVAL BY THE WATER DIVISION. METER BOXES SHALL BE INSTALLED CLEAR OF DRIVEWAY APPROACHES AND ADA ACCESSIBLE PATHS OF TRAVEL.
5. ALL HOT TAPPING METHODS SHALL REQUIRE PRIOR APPROVAL BY THE WATER DIVISION.
6. ALL DISTURBED LANDSCAPE FEATURES AND CONCRETE SIDEWALK SHALL BE RESTORED TO PRECONSTRUCTION CONDITION OR BETTER.
7. "NO-OX-ID A SPECIAL" GREASE SHALL BE APPLIED WHERE APPLICABLE AND AS DIRECTED BY THE ENGINEER OR DESIGNEE.
- \* 8. WHEN APPROVED BY THE WATER DIVISION, COPPER PIPE SHALL BE INSTALLED WITH PIPE SLEEVES, AND POLYETHYLENE TAPE SHALL BE USED TO FULLY SEAL BOTH ENDS OF THE PIPE SLEEVES.
9. COUPLINGS SHALL NOT BE USED UNLESS APPROVED BY THE WATER DIVISION.

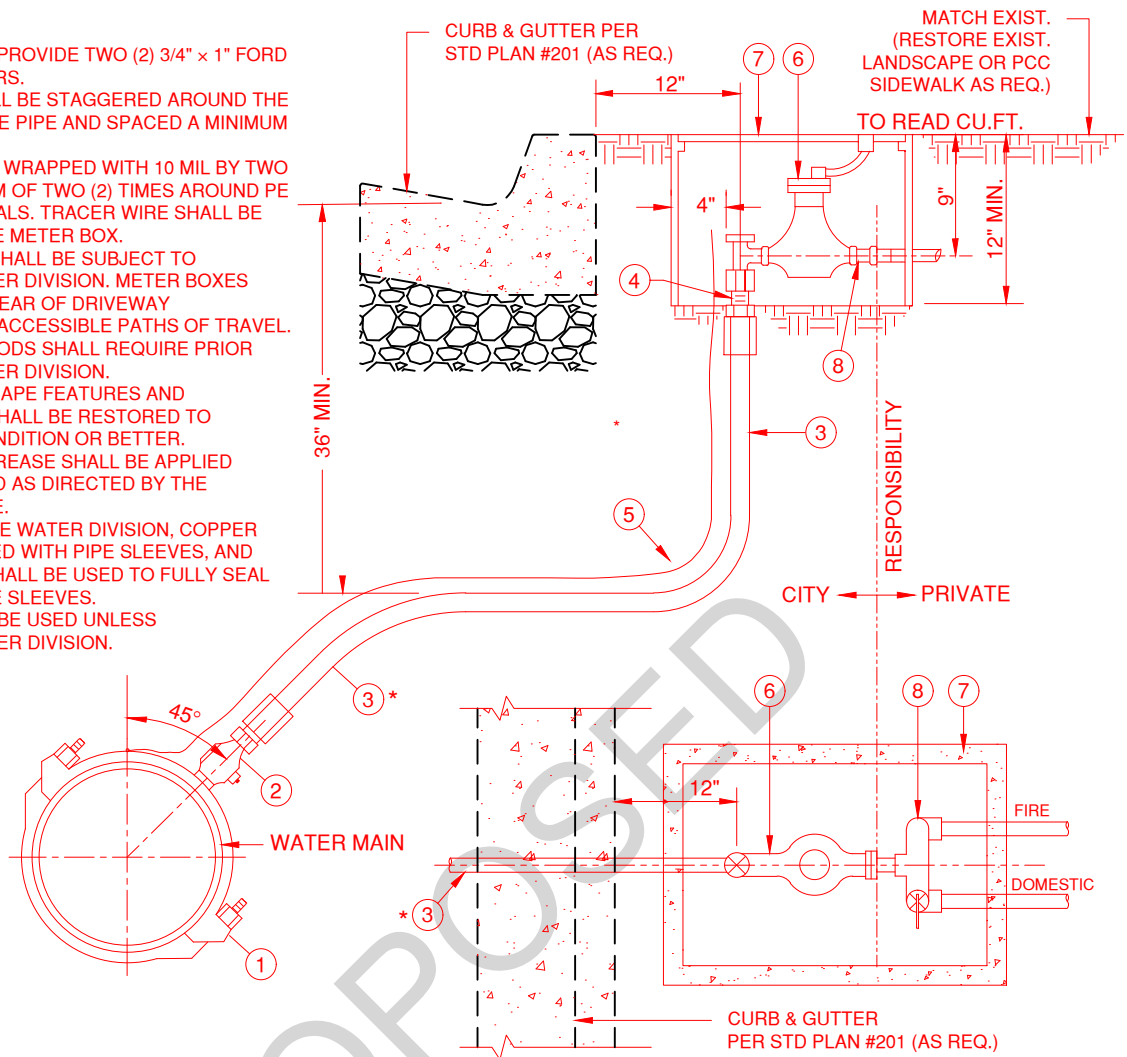

NO.	DESCRIPTION
①	<u>P.V.C. PIPE SADDLE:</u> SHALL BE FORD 202 BS BRONZE BODY/STAINLESS STEEL STRAP DOUBLE BAND OR APPROVED EQUAL. <u>A.C. PIPE SADDLE:</u> SHALL BE FORD 202 B IP4 DOUBLE STRAP BRONZE OR APPROVED EQUAL.
②	1" CORPORATION STOP FORD FB700-4-NL WITH FORD PACK JOINT COUPLING C04-44CTS OR APPROVED EQUAL. ADD FORD COPPER RING SL C-4.
③	REHAU MUNICIPEX SDR9 (CTS) PART NO. 261076 OR APPROVED EQUAL, WITH FORD STAINLESS STEEL INSERT 52 ON BOTH ENDS.
④	1" FORD ANGLE METER STOP #BA-43-44W-NL OR APPROVED EQUAL, LOCKABLE.
⑤	PLASTIC COATED 14 GAUGE COPPER TRACER WIRE FOR FUTURE DETECTION. FULL LENGTH OF PE PIPE.
⑥	METER: IPERL METAL 100CI2 TR/PL HOUSING WITH 2 WIRE IPERL PIGTAIL
⑦	METER BOX: ARMORCAST POLYMER CONCRETE BOX# AG1728BB12. SEE NOTE #5 FOR LOCATION REQUIREMENTS. SOFTSCAPE COVER: #AG1728WV0S050H02 HARDSCAPE COVER: ARMORCAST 20K #AG1728WW0S050H02.
⑧	8A FIRESETTER FORD #LTBA113-444W-AWT-NL 8B (2) ANGLE METER COUPLING - FORD PART #L38-44-NL 8C (2) METER COUPLING BUSHING - FORD PART #BBIM-44-NL

APPROVED BY:

VINNY T. HOANG  
CITY ENGINEER

ADOPTED DATE: MAY 13, 2026



**City of Westminster**  
DEPARTMENT OF PUBLIC WORKS

**1" SERVICE LINE WITH FIRE CONNECTION DETAIL (RESIDENTIAL APPLICATION)**

STANDARD PLAN NO.

**401-B**

**Water Standard Plan 403-A**  
**– Gate Valve Installation**

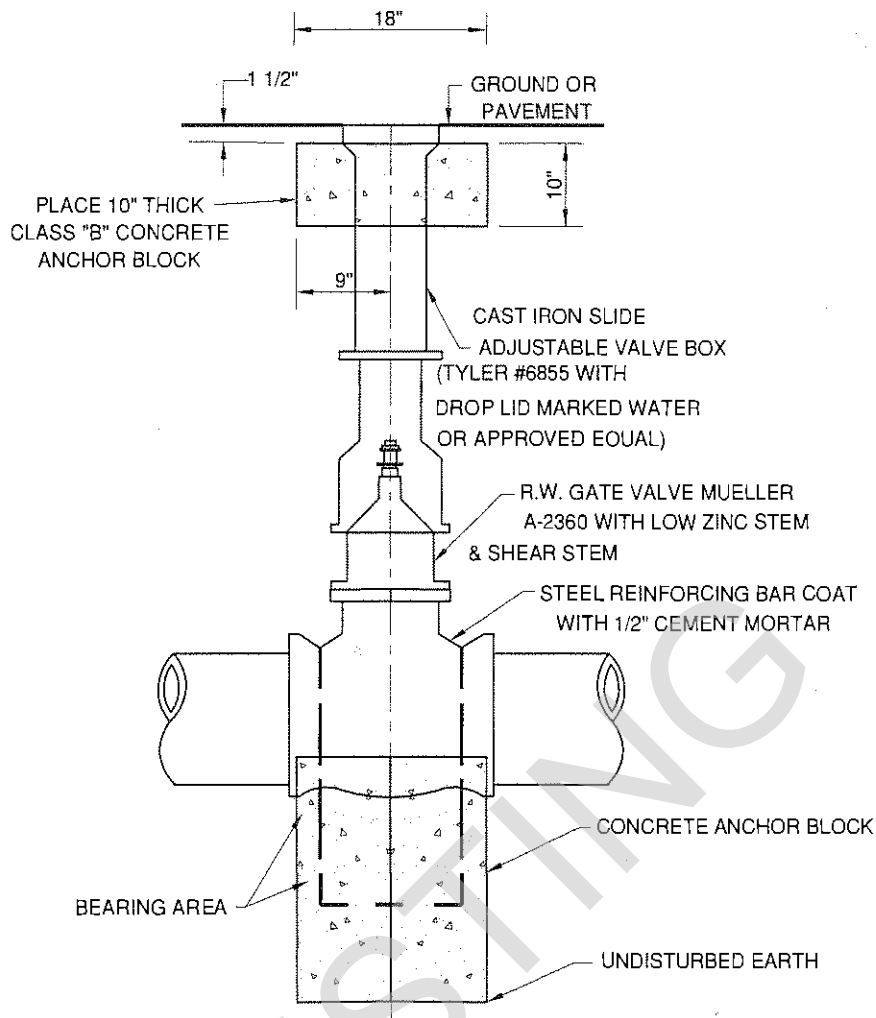

**NOTES:**

- 1- BELOW VALVE OPERATING NUT THERE WILL BE AN OVER-TORQUED SHEAR GROOVE PER MANUFACTURER'S SPECIFICATIONS.
- 2- STEEL REINFORCING BARS SHALL BE NO. 5 FOR VALVES LESS THAN 8" IN SIZE AND NO. 6 FOR VALVES 8" AND LARGER.
- 3- CLEAN AND PAINT VALVE CAN LIDS:  
 BLUE: MAINLINE VALVE LIDS  
 RED: HYDRANT VALVE LIDS
- 4- PLACE VALVE MARKERS / ARROWS ON CURB (Z - MARKERS) (CONTACT WATER DIVISION FOR DETAILS)

5- ALL R.W. GATE VALVES INSTALLED IN STREET INTERSECTIONS TO BE LOCATED AT B.C.R.'S

6- CONCRETE ANCHOR BLOCKS SHALL BE 5-B-2000 BEARING AREA FOR BLOCKS SHALL BE AS FOLLOWS.

VALVE SIZE	BEARING AREA
4"-6"	4 S.F.
8"	7 S.F.
10"	10 S.F.
12"	15 S.F.

7. PLACE BLUE REFLECTOR MARKER FOR HYDRANT PER STD.# 417

APPROVED:

*Maman Youssef*  
 P.W. DIRECTOR / CITY ENGINEER



**City of Westminster**  
 DEPARTMENT OF PUBLIC WORKS

**GATE VALVE  
 INSTALLATION**

STANDARD NUMBER

**403**

REVISED DATE: 5/16/08

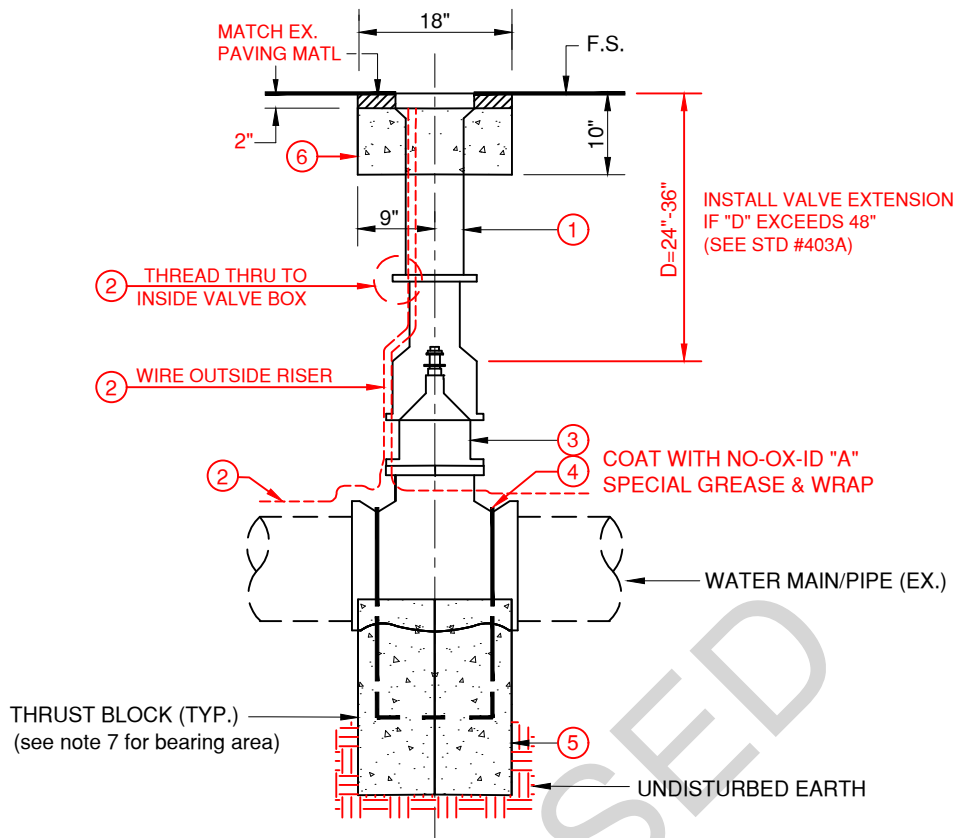

**NOTES:**

1. BELOW VALVE OPERATING NUT THERE WILL BE AN OVER-TORQUED SHEAR GROOVE PER MANUFACTURER'S SPECIFICATIONS.
2. STEEL REINFORCING BARS SHALL BE NO. 5 FOR VALVES LESS THAN 8" IN SIZE & NO. 6 FOR VALVES 8" AND LARGER.
3. CLEAN AND PAINT VALVE CANS LIDS:  
 BLUE — MAINLINE VALVE LIDS  
 RED — HYDRANT VALVE LIDS
4. PLACE VALVE MARKERS / ARROWS ON CURB (Z-MARKERS) (CONTACT WATER DIVISION FOR DETAILS)
5. ALL R.W. GATE VALVES INSTALLED IN STREET INTERSECTIONS TO BE LOCATED AT B.C.R.'s
6. CONCRETE STRENGTH AND CORRESPONDING CONCRETE CLASS SHALL CONFORM TO THE REQUIREMENTS OF SECTION 201-1, PORTLAND CEMENT CONCRETE, OF THE LATEST EDITION OF THE "GREENBOOK", CEMENT SHALL BE TYPE II OR V.
7. BEARING AREA FOR BLOCKS SHALL BE AS FOLLOWS:
 

VALVE SIZE	BEARING AREA
4"-6"	4 S.F.
8"	7 S.F.
10"	10 S.F.
12"	15 S.F.
8. PLACE BLUE REFLECTOR MARKER FOR HYDRANT PER STANDARD PLAN NO. 417.

NO.	DESCRIPTION
①	CAST IRON SLIDE ADJUSTABLE VALVE BOX (TYLER #6855 WITH DROP LID MARKED "WATER" OR APPROVED EQUAL)
②	TRACER WIRE
③	R.W. GATE VALVE MUELLER / U.S. VALVE A-2362 WITH LOW ZINC STEM & SHEAR STEM
④	STEEL REINFORCING BAR SHALL BE COATED WITH NO-OX-ID "A" SPECIAL GREASE & WRAPPED
⑤	CONCRETE ANCHOR BLOCK, SEE GENERAL NOTE #6 FOR MORE DETAILS
⑥	CONSTRUCT 10" THICK CLASS "B" CONCRETE ANCHOR BLOCK

APPROVED BY:

VINNY T. HOANG  
CITY ENGINEER

ADOPTED DATE: MAY 13, 2026



**City of Westminster**  
DEPARTMENT OF PUBLIC WORKS

**GATE VALVE  
INSTALLATION**

STANDARD PLAN NO.

**403-A**

**Water Standard Plan 403-B**  
**- Valve Stem Extension**  
**(New)**

**NOTES:**

1. PROVIDE VALVE STEM EXTENSIONS WHERE DEPTH TO OPERATING NUT EXCEEDS 48 INCHES FROM FINISHED GRADE. EXTENSIONS SHALL BE FABRICATED TO FIELD MEASUREMENTS.
2. VALVE STEM EXTENSIONS SHALL NOT BE LESS THAN 24 INCHES IN LENGTH AND SHALL TERMINATE BETWEEN 24" TO 36" BELOW FINISHED GRADE.
3. VALVE STEM EXTENSIONS SHALL BE FIBERPLAS BY PIPELINE PRODUCTS, SAN MARCOS, CA OR ENGINEER-APPROVED EQUAL.

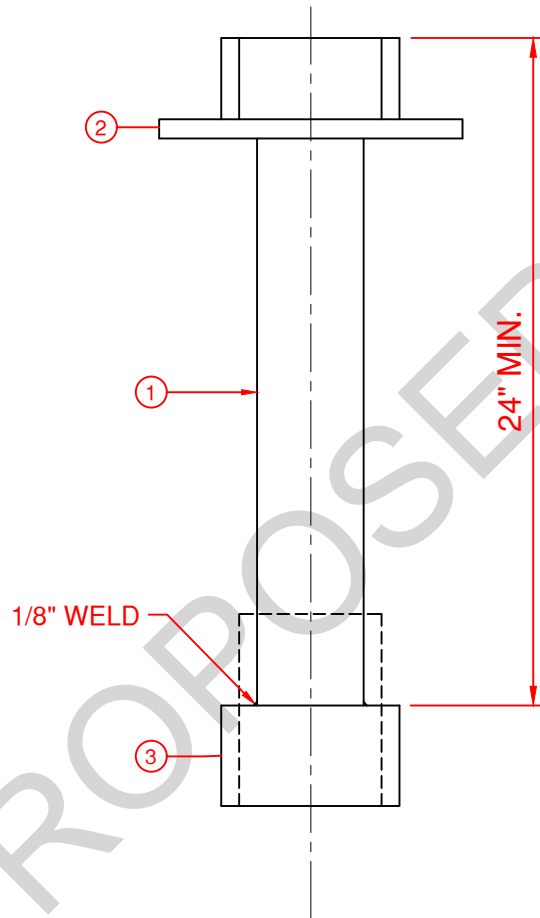

NO.	DESCRIPTION
①	2-INCH SQUARE FIBERPLAS EXTENTION TUBING
②	FIBERPLAS UPPER OPERATING NUT WITH CENTERING RING - RING DIAMETER SHALL BE IN ACCORDANCE WITH THE MANUFACTURER'S RECOMMENDATIONS FOR USE WITH AN 8-INCH RISER
③	FIBERPLAS LOWER OPERATING NUT

APPROVED BY:

VINNY T. HOANG  
CITY ENGINEER

ADOPTED DATE: MAY 13, 2026



**City of Westminster**  
DEPARTMENT OF PUBLIC WORKS

**VALVE STEM EXTENSION**

STANDARD PLAN NO.

**403-B**

**Water Standard Plan 403-C**  
**– 4", 6", 8" or 12" Cut-In Valve (New)**

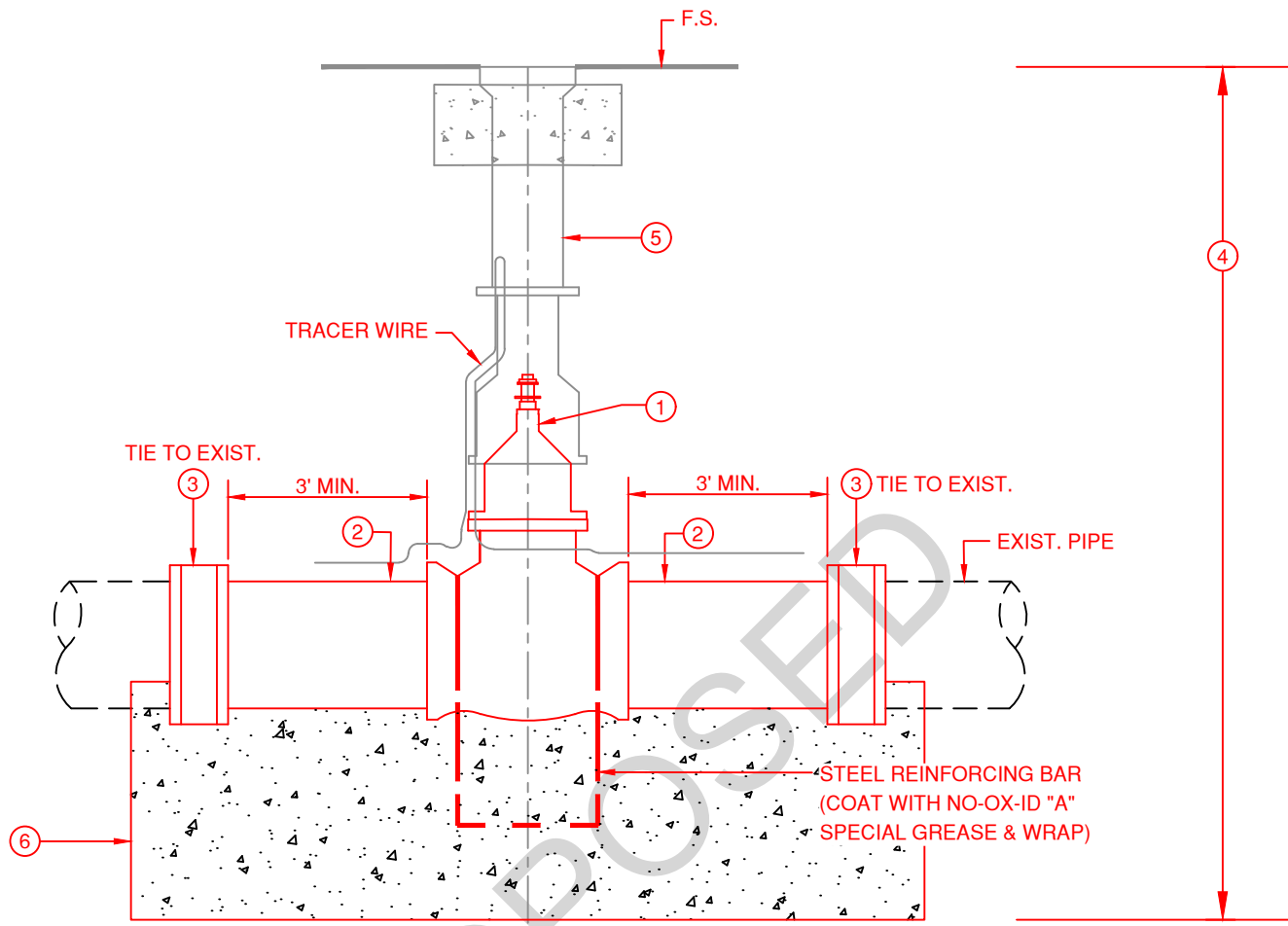

**NOTES:**

1. CONTRACTOR/APPLICANT SHALL REFER TO WATER NOTES FOR ADDITIONAL REQUIREMENTS.
2. REPLACEMENT PIPE, VALVE, AND FITTINGS SHALL BE CLEANED AND DISINFECTED IN ACCORDANCE WITH WATER NOTES AND CITY STANDARD REQUIREMENTS FOR DISINFECTION OF WATER MAINS.
3. APPLY NO-OX-ID "A SPECIAL WW" GREASE AND WRAP TO ALL VALVES, COUPLINGS, AND METALLIC FITTINGS. WRAP AND COVER WITH POLYETHYLENE ENCASEMENT PER AWWA C105.

NO.	DESCRIPTION
①	MECHANICAL JOINT VALVE WITH GRIP RING AND STAINLESS-STEEL FASTENERS, MUELLER A-2362, FEATURING A LOW ZINC STEM AND SHEAR STEM. THE NOMINAL SIZE SHOULD MATCH THAT OF THE EXISTING MAIN.
②	PIPE MAIN (P.V.C. C900 DR-18)
③	TRANSITION COUPLING, FC2W WITH 316 S.S. FASTENERS OR ENGINEER-APPROVED EQUAL.
④	FOR EXCAVATION, BACKFILL, AND COMPACTION REQUIREMENTS, REFER TO STD PLAN NO. 609
⑤	REFER TO STD PLAN NO. 403 FOR VALVE BOX ASSEMBLY AND STD PLAN NO. 403A FOR VALVE STEM EXTENSION.
⑥	THRUST BLOCK PER STD PLAN NO. 402

APPROVED BY:

VINNY T. HOANG  
CITY ENGINEER

ADOPTED DATE: MAY 13, 2026



**City of Westminster**  
DEPARTMENT OF PUBLIC WORKS

**4", 6", 8" OR 12" CUT-IN VALVE**

STANDARD PLAN NO.

**403-C**

**Water Standard Plan 403-D**  
**– Waterline Cut-Out (Valves, Tees, & Crosses)**

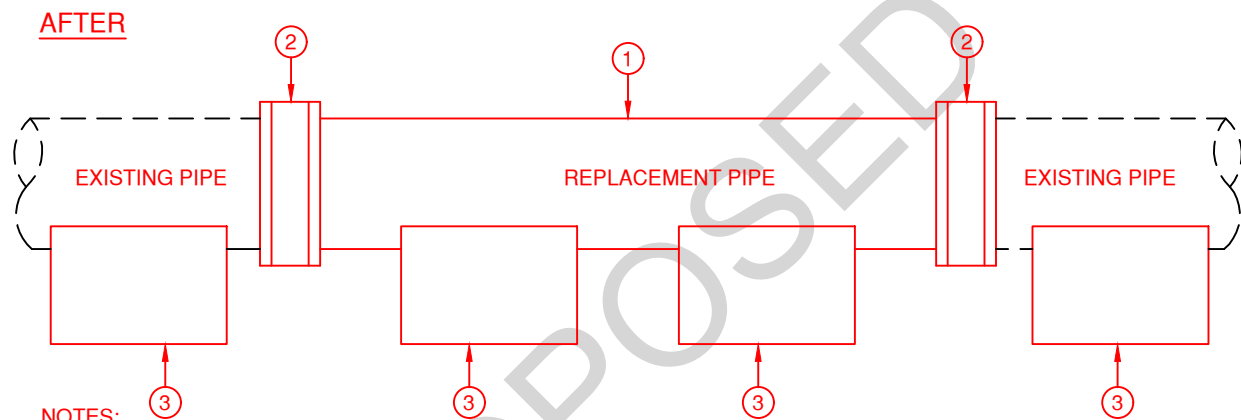
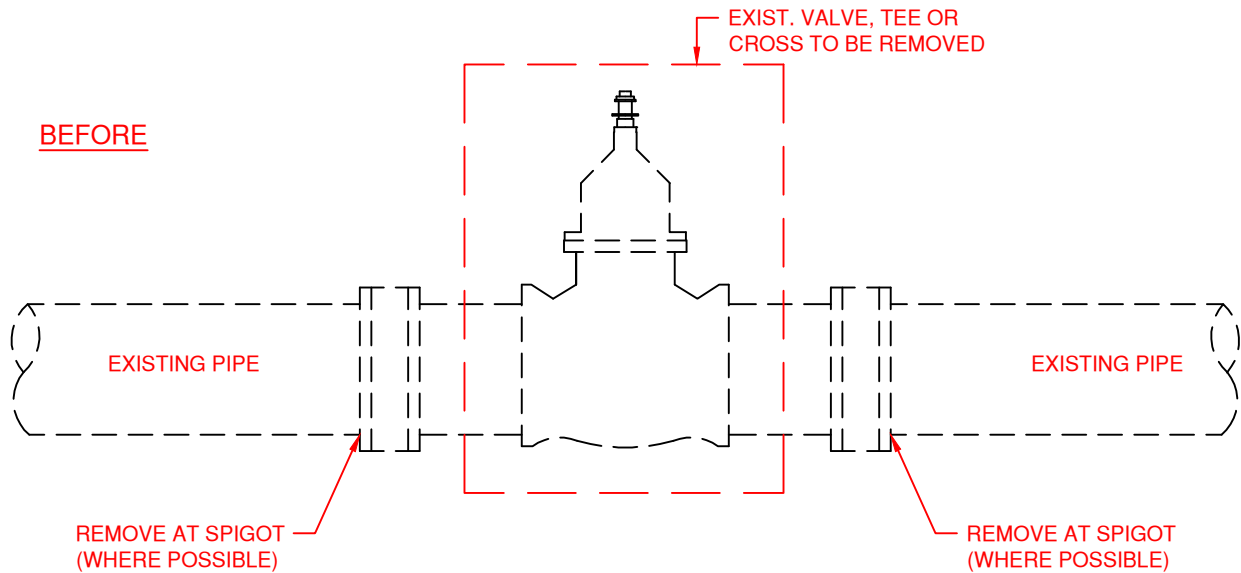

**NOTES:**

1. THE USE OF FULL-CIRCLE REPAIR CLAMPS IS STRICTLY PROHIBITED.
2. BACKFILLING SHALL NOT COMMENCE UNTIL LINE PRESSURE HAS BEEN RESTORED AND ALL CONNECTIONS HAVE BEEN INSPECTED AND APPROVED FOR LEAKAGE BY THE WATER DIVISION.
3. REPLACEMENT PIPES AND FITTINGS SHALL BE CLEANED AND DISINFECTED IN ACCORDANCE WITH THE WATER NOTES AND THE STANDARD REQUIREMENTS FOR DISINFECTING WATER MAINS.
4. WHERE EXISTING PIPE MATERIALS ARE CAST IRON (CI), DUCTILE IRON (DI), OR ASBESTOS CEMENT (AC), APPROVED TRANSITION COUPLINGS MUST BE PROVIDED AT BOTH ENDS OF THE REPLACEMENT PIPE.
5. ABANDONED PIPES SHALL BE SEALED IN ACCORDANCE WITH STANDARD PLAN NO. 419.
6. EXCAVATION, BACKFILL, AND COMPACTION REQUIREMENTS PER STANDARD PLAN NO. 609.
7. CONTRACTOR/APPLICANT SHALL REFER TO WATER NOTES FOR ADDITIONAL REQUIREMENTS.
8. ALL HARDWARE SHALL BE OF TYPE 316 STAINLESS STEEL UNLESS OTHERWISE APPROVED BY THE CITY ENGINEER.
9. APPLY NO-OX-ID " A SPECIAL WW" GREASE TO ALL BURIED HARDWARE AND METALLIC FITTINGS, AND PROVIDE POLYETHYLENE ENCASEMENT IN ACCORDANCE WITH AWWA C105.WA C105.

NO.	DESCRIPTION
①	P.V.C. C900 DR-18 (REPLACEMENT PIPE, MINIMUM LENGTH OF REPLACEMENT SHALL BE 48 INCHES)
②	PIPE COUPLING - FORD FC2W WITH 316 S.S. FASTENERS OR ENGINEER APPROVED EQUAL (INSTALL PER MANUFACTURER'S RECOMMENDATION)
③	PIPE SUPPORT (SAND BAGS OR TRENCH BOTTOM) AS NECESSARY OR AS DIRECTED BY CITY ENGINEER

APPROVED BY:

VINNY T. HOANG  
CITY ENGINEER

ADOPTED DATE: MAY 13, 2026



**City of Westminster**  
DEPARTMENT OF PUBLIC WORKS

**WATERLINE CUT-OUT  
(VALVES, TEES & CROSSES)**

STANDARD PLAN NO.

**403-D**

**Water Standard Plan 408**  
**– 3” and Larger Metered Water Service**

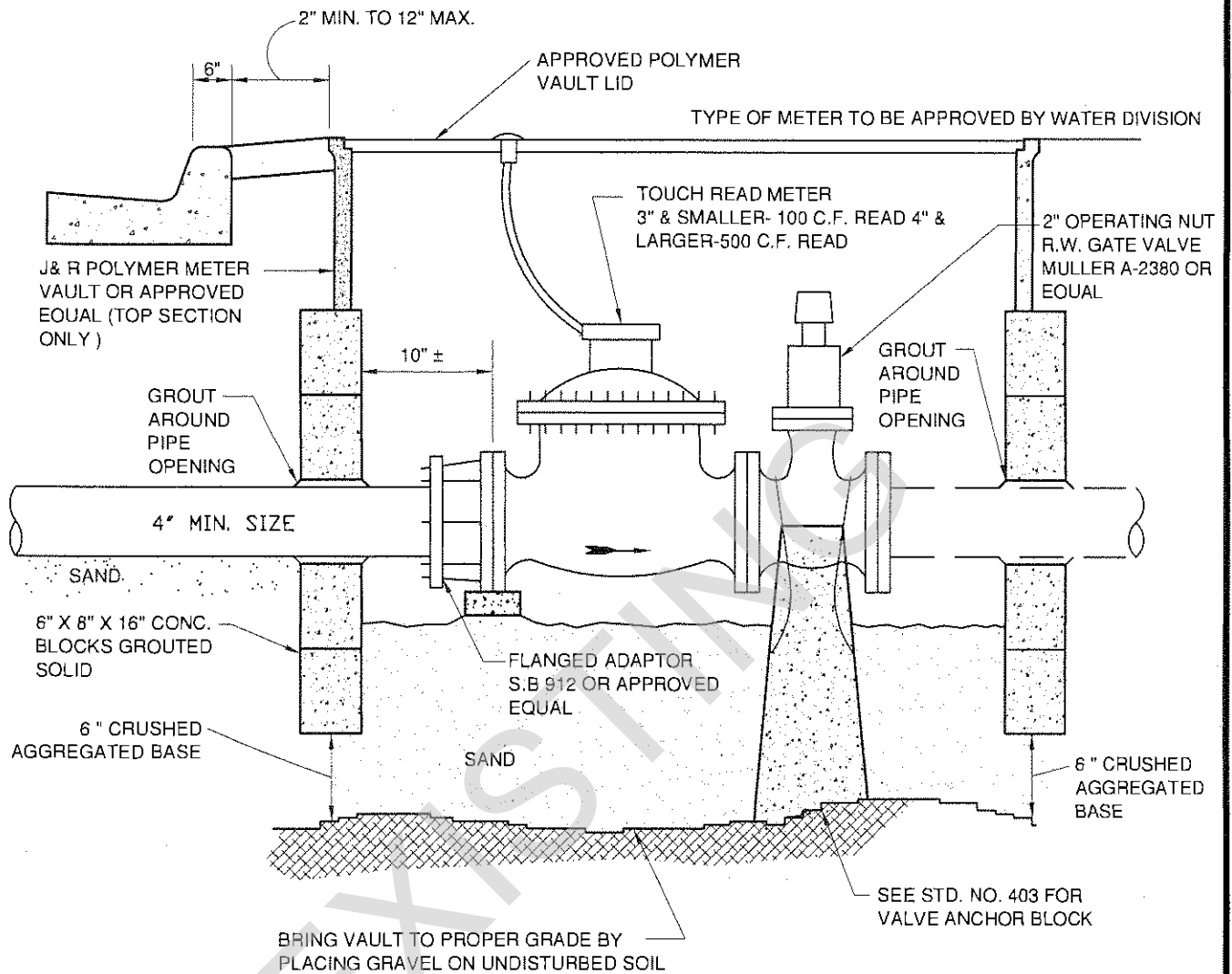

**NOTE:**

- \* TAPPING MUELLER VALVE OR OTHER VALVE MUST BE INSTALLED BETWEEN METER VAULT & MAIN LINE.
- \* VALVE TO BE INSTALLED PER STANDARD #403 ADJACENT TO WATER MAIN.

APPROVED:

*Mawwa Yousse*  
P.W. DIRECTOR / CITY ENGINEER



**City of Westminster**

DEPARTMENT OF PUBLIC WORKS

3" AND LARGER  
METERED WATER SERVICE

STANDARD NUMBER

408

REVISED DATE: 5/15/08

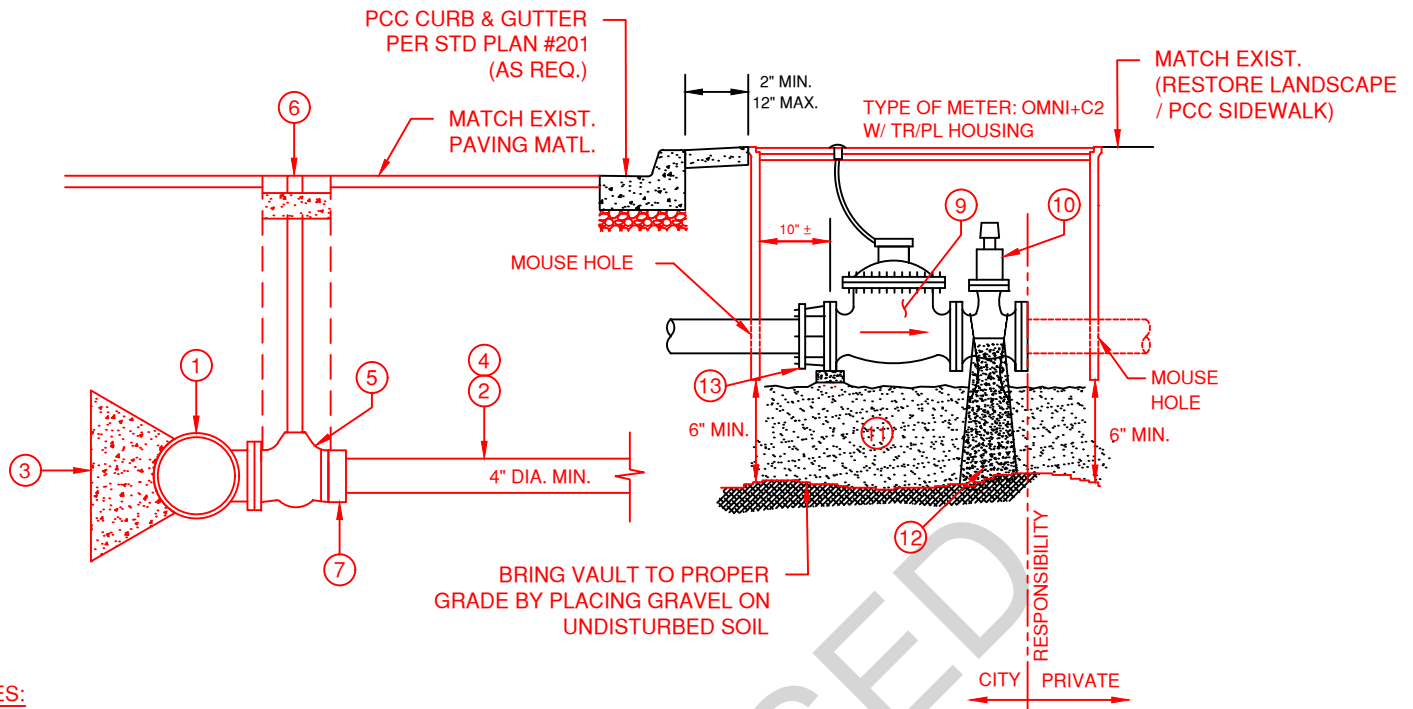

**NOTES:**

1. INSTALL A MUELLER TAPPING VALVE OR AN ENGINEER-APPROVED EQUIVALENT BETWEEN THE METER VAULT AND THE WATER MAIN.
2. INSTALL A VALVE ADJACENT TO THE WATER MAIN IN ACCORDANCE WITH STANDARD PLAN NO. 403.
3. CONTRACTOR SHALL CUT INLET AND OUTLET PIPE MOUSE HOLES IN THE VAULT USING A DIAMOND BLADE CUTTER. PROVIDE A MINIMUM OF 1 INCH AND A MAXIMUM OF 2 INCHES OF CLEARANCE BETWEEN THE VAULT OPENINGS AND THE PIPE.

NO.	DESCRIPTION
①	JCM 432 ALL STANDARD STAINLESS STEEL TAPPING SLEEVE OR ENGINEER APPROVED EQUAL
②	6" P.V.C PIPE CLASS 150 C-900 DR18
③	CONCRETE THRUST BLOCK PER CITY OF WESTMINSTER STD PLAN 402.
④	PLASTIC COATED 14 GAUGE COPPER TRACER WIRE SHALL BE INSTALLED ON TOP OF PVC PIPE. THE WIRE WILL BE WRAPPED WITH 10 MIL. 2-INCH-WIDE PIPE WRAP, WITH TWO WRAPS AROUND THE PIPE EVERY 5 FEET. THE TRACER WIRE SHALL BE TERMINATED AND SECURED AROUND THE BOLT AT THE FLANGE COUPLING ADAPTER.
⑤	FLG.X M.J. R.W. GATE VALVE MUELLER A-2362 OR ENGINEER APPROVED EQUAL.
⑥	VALVE BOX & ANCHOR BLOCK PER STANDARD PLAN 403.
⑦	ROMAC GRIP-RING
⑧	<b>ARMORCAST VAULTS:</b> 3", 4", 6" METER: A6001833TAX48MT-H2 ; 8" METER: A6001506TAP48MT-H2; 10" METER: A6001449TAP48MT-H2
⑨	METER: OMNI+C2 WITH TR/PL HOUSING
⑩	2" OPERATING NUT R.W. GATE VALVE MULLER A-2382 OR ENGINEER APPROVED EQUAL (SEE STANDARD PLAN 403).
⑪	MINIMUM 6" CRUSHED AGGREGATE BASE
⑫	VALVE ANCHOR BLOCK PER STD PLAN 403
⑬	FORD FCA EPOXY COATED WITH 304 STAINLESS FASTENERS OR ENGINEER APPROVED EQUAL.

APPROVED BY:

VINNY T. HOANG  
CITY ENGINEER

ADOPTED DATE: MAY 13, 2026



**City of Westminster**  
DEPARTMENT OF PUBLIC WORKS

**3" AND LARGER  
METERED WATER SERVICE**

STANDARD PLAN NO.

**408**

**Water Standard Plan 413**  
**– 2” Service Installation**

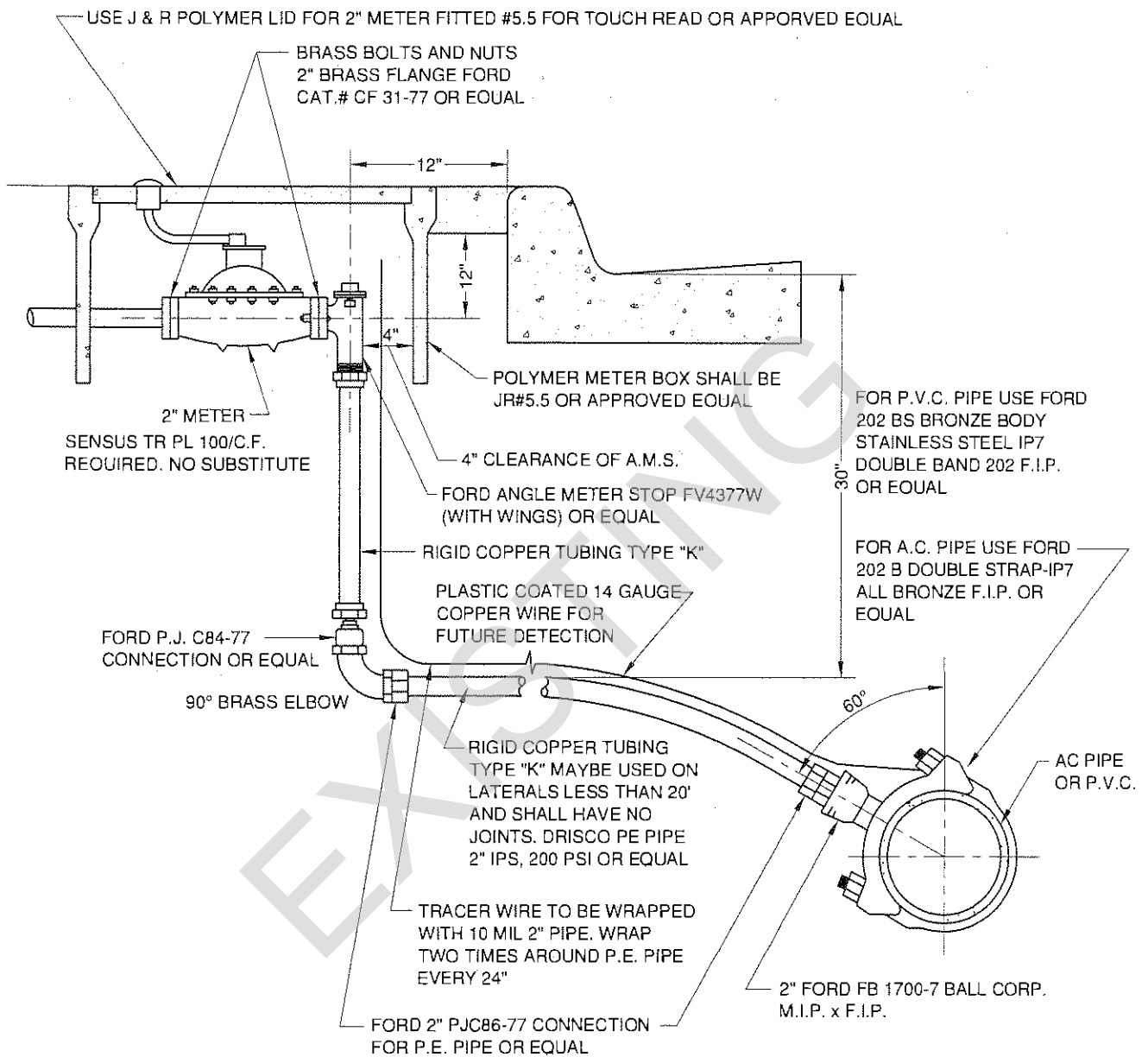

APPROVED:

*Marwan Youss*  
P.W. DIRECTOR / CITY ENGINEER



**City of Westminster**  
DEPARTMENT OF PUBLIC WORKS

REVISED DATE: 5/15/08

2" SERVICE  
INSTALLATION

STANDARD NUMBER

413

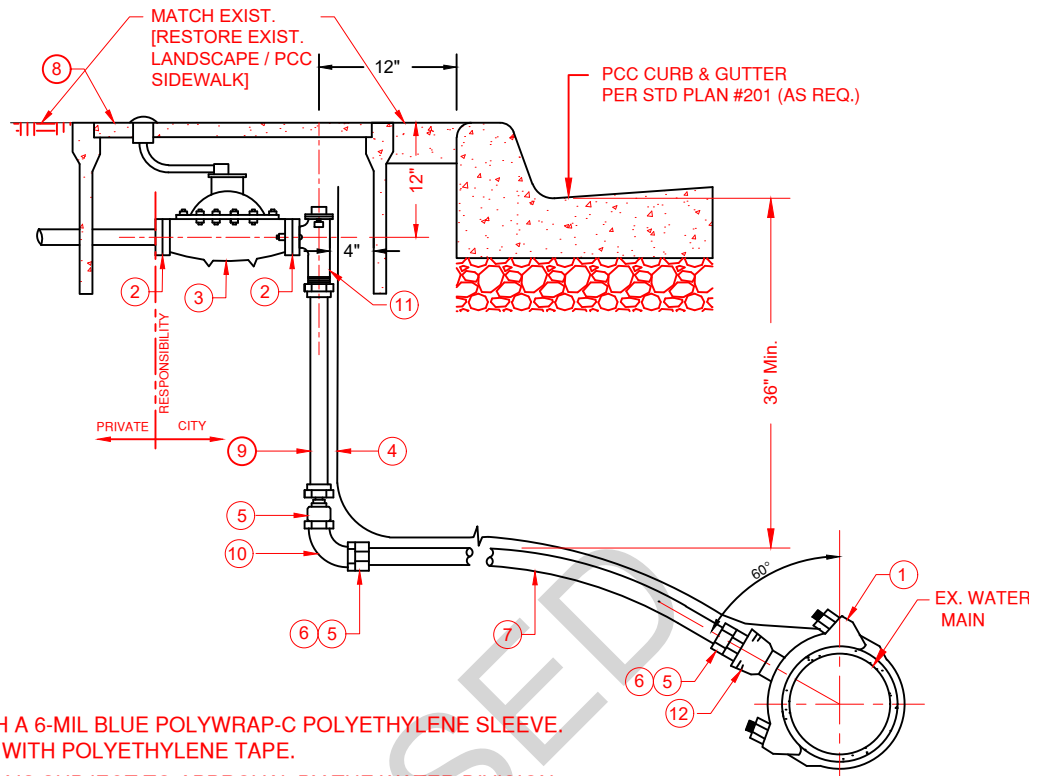

**NOTES:**

1. WRAP RIGID COPPER TUBING WITH A 6-MIL BLUE POLYWRAP-C POLYETHYLENE SLEEVE. SEAL BOTH ENDS OF THE SLEEVE WITH POLYETHYLENE TAPE.
2. THE LOCATION OF THE METER BOX IS SUBJECT TO APPROVAL BY THE WATER DIVISION. LOCATE METER BOXES AWAY FROM DRIVEWAY APPROACHES AND ADA-ACCESSIBLE PATHWAYS.
3. ALL HOT TAPPING PROCEDURES REQUIRE PRIOR APPROVAL FROM THE WATER DIVISION.
4. RESTORE ALL DISTURBED LANDSCAPE FEATURES AND CONCRETE SIDEWALKS TO MATCH EXISTING CONDITIONS.
5. APPLY NO-OX-ID " A SPECIAL" GREASE WHERE APPLICABLE AND AS DIRECTED BY THE ENGINEER OR DESIGNEE.

NO.	DESCRIPTION
①	<u>P.V.C. PIPE SADDLE</u> SHALL BE FORD 202 BS BRONZE BODY/STAINLESS STEEL STRAP DOUBLE BAND OR APPROVED EQUAL. <u>A.C. PIPE SADDLE</u> SHALL BE FORD 202 B IP4 DOUBLE STRAP BRONZE OR APPROVED EQUAL.
②	BRASS BOLTS AND NUTS (2" BRASS FLANGE FORD CAT #CF31-77 OR APPROVED EQUAL)
③	1.5-INCH METER: 1.5" OMNI+ C2 100CF, WITH TR/PL HOUSING 2-INCH METER: 2" OMNI+ C2 T2 BODY 100CF, WITH TR/PL HOUSING
④	TRACER WIRE TO BE WRAPPED WITH 10 MIL PIPE WRAP TWO TIMES AROUND P.E. PIPE EVERY TWO FEET.
⑤	FORD PACK JOINT COUPLING: CATALOG NO. C84-77 NL (2" DIA.)
⑥	FORD INSERT STIFFENER - INSERT-55 (ONLY FOR P.E. PIPES)
⑦	2" REHAU MUNICIPEX SDR9 (CTS) PART NO. 261136 OR APPROVED EQUAL, WITH FORD STAINLESS STEEL INSERT 55 ON BOTH ENDS. RIGID COPPER TUBING TYPE "K" MAY BE USED ON LATERALS LESS THAN 20' WITH WATER DIVISION APPROVAL. COUPLING SHALL NOT BE USED UNLESS APPROVED BY THE WATER DIVISION.
⑧	<u>METER BOX:</u> ARMORCAST POLYMER CONCRETE BOX# AG1728BB12. <u>SOFTSCAPE COVER:</u> #AG1728WV0S050H02 <u>HARDSCAPE COVER:</u> ARMORCAST 20K #AG1728WW0S050H02.
⑨	RIGID COPPER TUBING TYPE "K" OR AS APPROVED BY THE WATER DIVISION.
⑩	90° BRASS ELBOW
⑪	FORD ANGLE METER STOP BFA43-777W-NL (WITH WINGS) OR APPROVED EQUAL
⑫	2" FORD FB 1700-7 BALL CORP. M.I.P. x F.I.P.

APPROVED BY:

VINNY T. HOANG  
CITY ENGINEER

ADOPTED DATE: MAY 13, 2026



**City of Westminster**

DEPARTMENT OF PUBLIC WORKS

**2" SERVICE  
INSTALLATION**

STANDARD PLAN NO.

**413**

**Water Standard Plan 420**  
**– Abandon 2” Service Line**

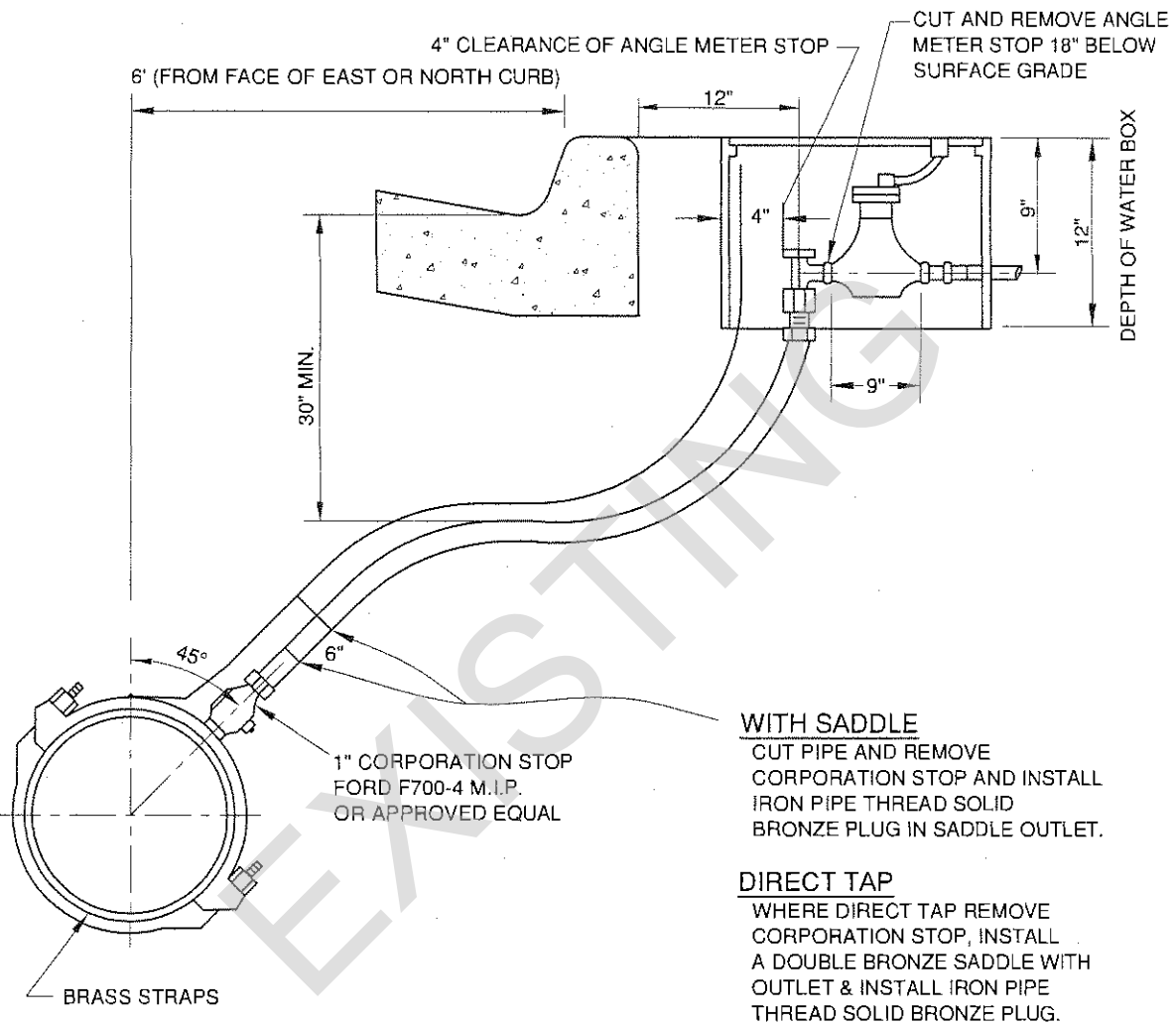

APPROVED:

*Marwa Jousse*  
P.W. DIRECTOR / CITY ENGINEER



**City of Westminster**  
DEPARTMENT OF PUBLIC WORKS

ABANDON 2"  
SERVICE LINE

STANDARD NUMBER

420

REVISED DATE: 5/15/08

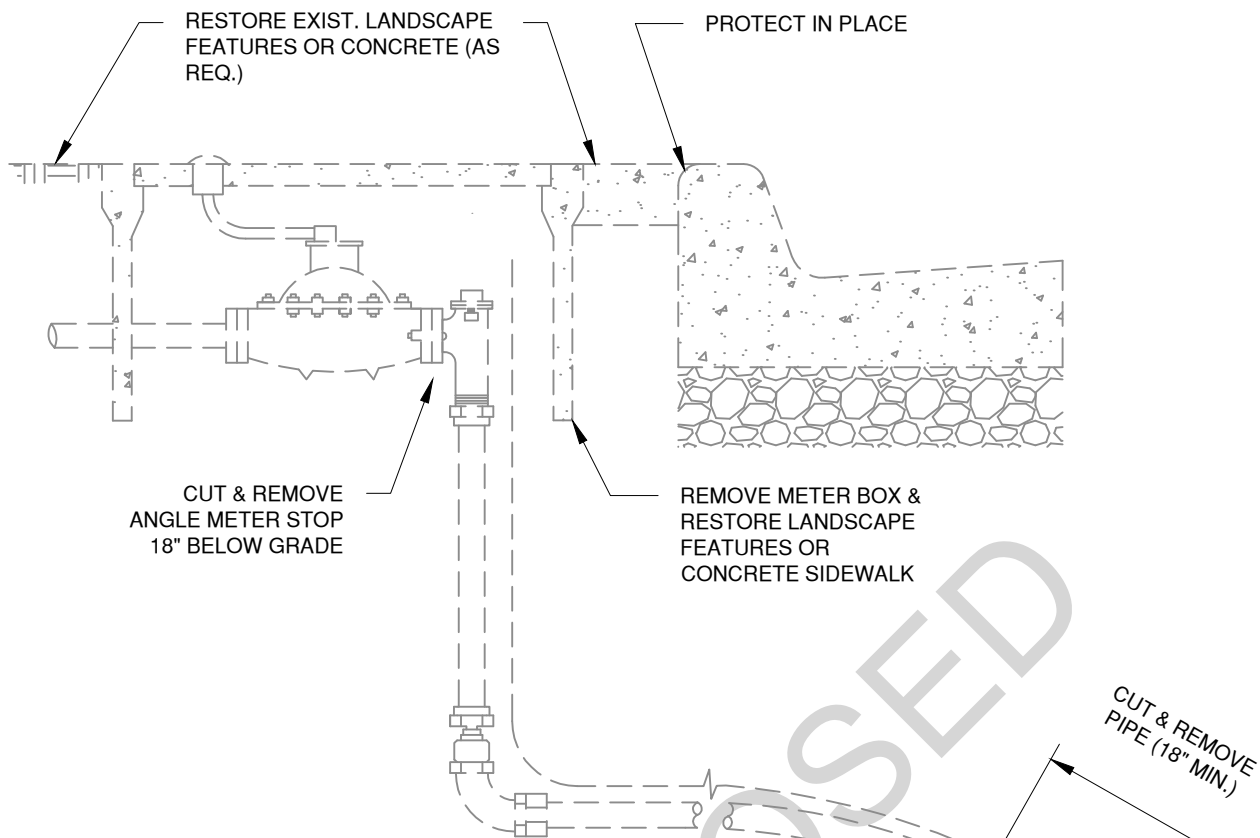

**WITH SADDLE (GOOD CONDITION)**

CUT PIPE, REMOVE THE CORPORATION STOP, AND INSTALL AN IRON PIPE THREAD SOLID BRONZE PLUG IN SADDLE OUTLET.

**DIRECT TAP**

WHERE A DIRECT TAP EXISTS, REMOVE THE CORPORATION STOP AND INSTALL A DOUBLE BRONZE SADDLE WITH A 2-INCH OUTLET AND AN IRON PIPE THREAD (IPT) SOLID BRONZE PLUG.

ALTERNATIVELY, INSTALL A FORD STAINLESS STEEL FULL-CIRCLE REPAIR CLAMP WHERE DIRECTED BY THE WATER DIVISION.

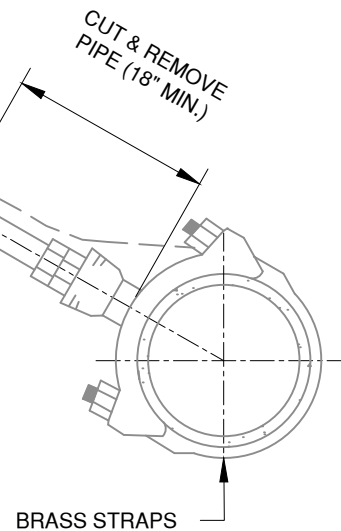

**NOTE:**

1. PRIOR TO ABANDONMENT, THE CONTRACTOR SHALL NOTIFY AND REQUEST INSPECTION BY THE WATER DIVISION TO VERIFY THE CONDITION OF THE PIPE AND SADDLE.
2. WHERE THE METER BOX IS LOCATED WITHIN LANDSCAPED AREAS, REMOVE THE BOX AND RESTORE ALL DISTURBED AREAS TO MATCH EXISTING CONDITIONS.
3. WHERE THE METER BOX IS LOCATED WITHIN SIDEWALK, REMOVE THE BOX AND REPLACE CONCRETE SIDEWALK FROM COLD JOINT TO COLD JOINT IN ACCORDANCE WITH STANDARD PLAN NO. 202 OR 203.

APPROVED BY:

VINNY T. HOANG  
CITY ENGINEER

ADOPTED DATE: MAY 13, 2026



**City of Westminster**

DEPARTMENT OF PUBLIC WORKS

**ABANDON 2"  
SERVICE LINE**

STANDARD PLAN NO.

**420**

**Water Standard Plan 421**  
**– Abandon  $\frac{3}{4}$ " or 1" Service Line**

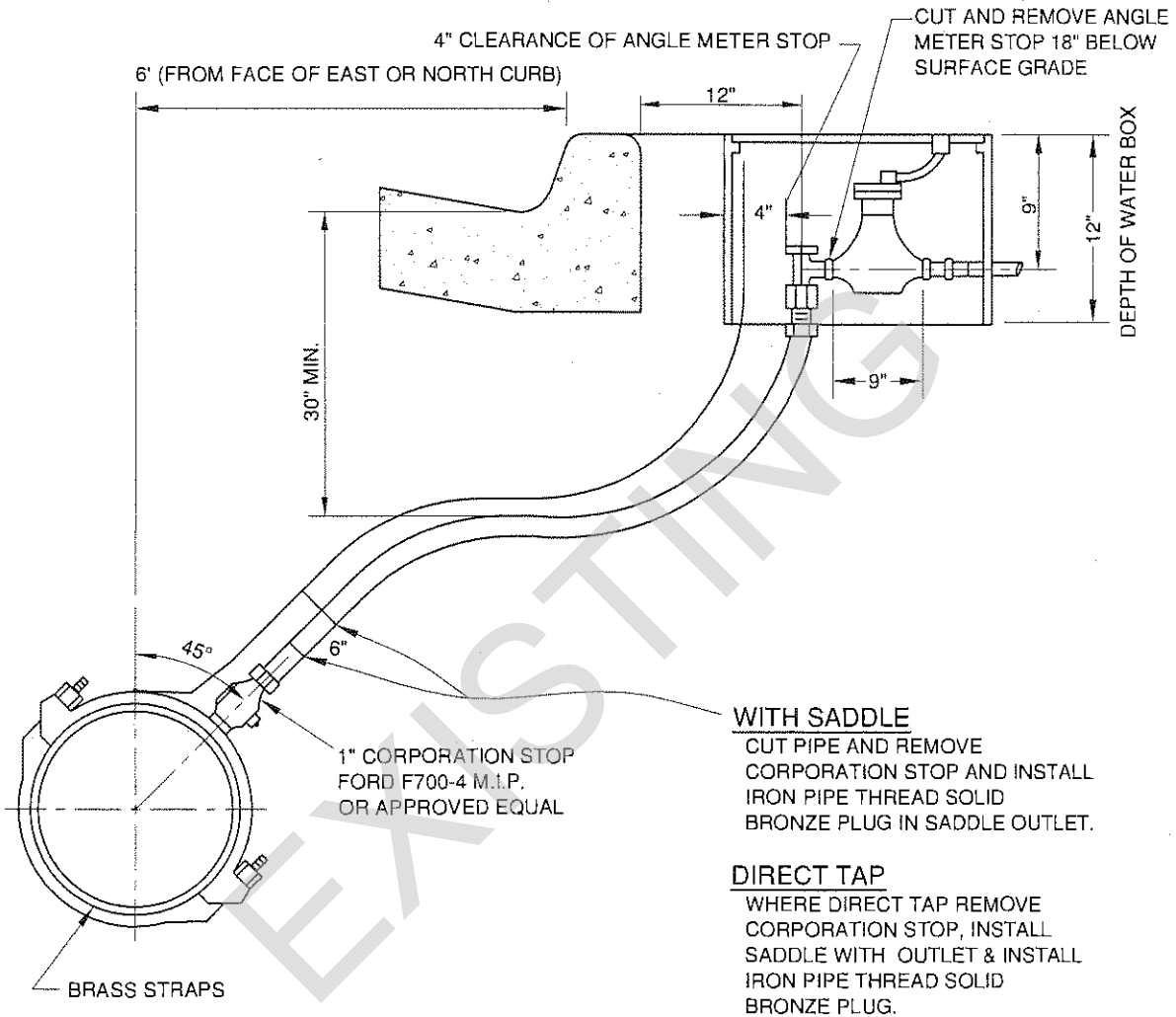

**WITH SADDLE**  
 CUT PIPE AND REMOVE CORPORATION STOP AND INSTALL IRON PIPE THREAD SOLID BRONZE PLUG IN SADDLE OUTLET.

**DIRECT TAP**  
 WHERE DIRECT TAP REMOVE CORPORATION STOP, INSTALL SADDLE WITH OUTLET & INSTALL IRON PIPE THREAD SOLID BRONZE PLUG.

APPROVED:

*Marwa Yousef*  
 P.W. DIRECTOR / CITY ENGINEER

REVISED DATE: 5/15/08



**City of Westminster**  
 DEPARTMENT OF PUBLIC WORKS

ABANDON 3/4", AND 1" SERVICE LINE

STANDARD NUMBER  
 421

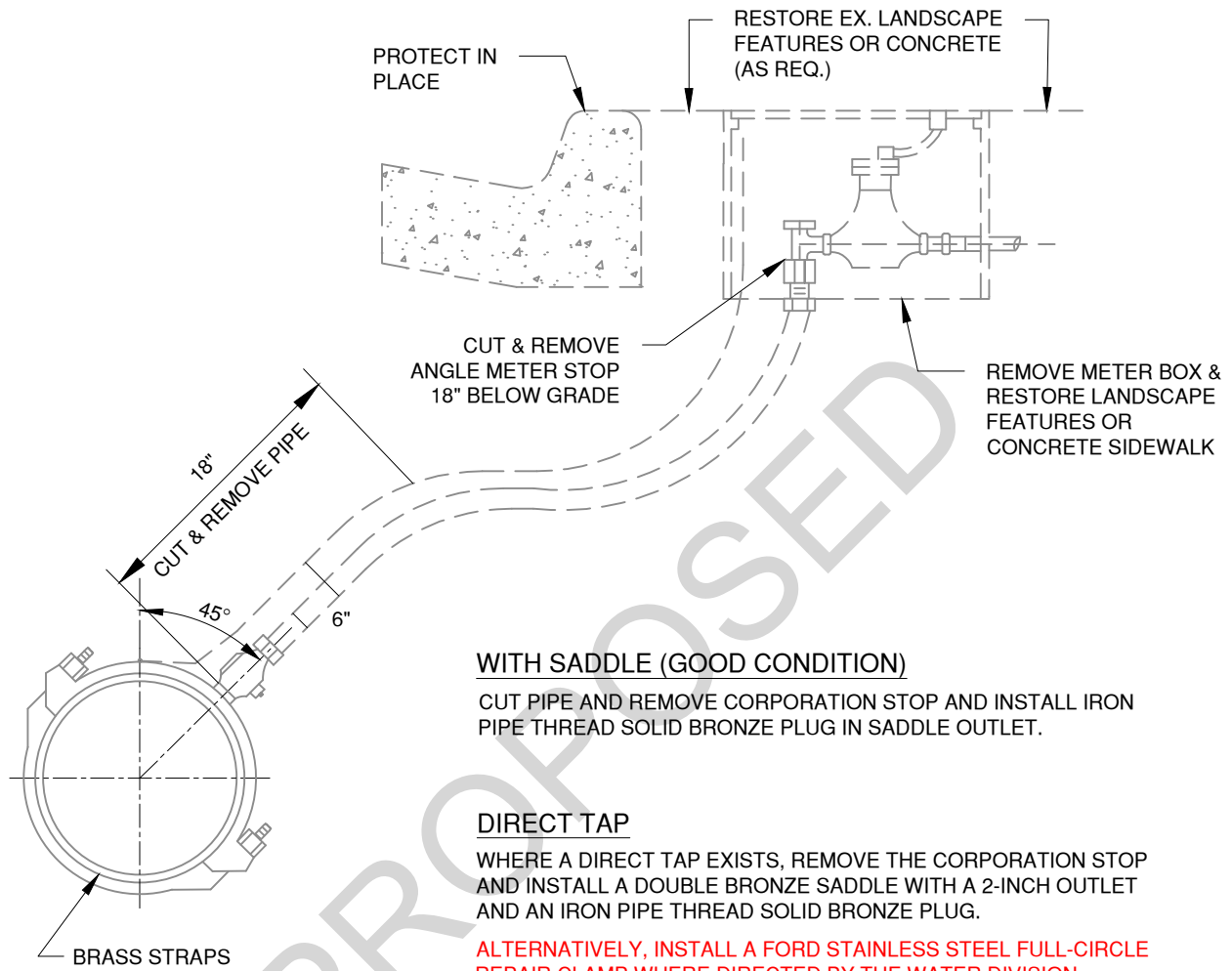

**NOTE:**

1. PRIOR TO ABANDONMENT, THE CONTRACTOR SHALL NOTIFY AND REQUEST INSPECTION BY THE WATER DIVISION TO VERIFY THE CONDITION OF THE PIPE AND SADDLE.
2. WHERE THE METER BOX IS LOCATED WITHIN LANDSCAPED AREAS, REMOVE THE BOX AND RESTORE ALL DISTURBED AREAS TO MATCH EXISTING CONDITIONS.
3. WHERE THE METER BOX IS LOCATED WITHIN SIDEWALK, REMOVE THE BOX AND REPLACE CONCRETE SIDEWALK FROM COLD JOINT TO COLD JOINT IN ACCORDANCE WITH STANDARD PLAN NO. 202 OR 203.

APPROVED BY:

VINNY T. HOANG  
 CITY ENGINEER

ADOPTED DATE: MAY 13, 2026



**City of Westminster**  
 DEPARTMENT OF PUBLIC WORKS

ABANDON 3/4", AND 1"  
 SERVICE LINE

STANDARD PLAN NO.

**421**

**Miscellaneous Standard Plan 609**  
**– Utility Excavation & Potholing Detail**

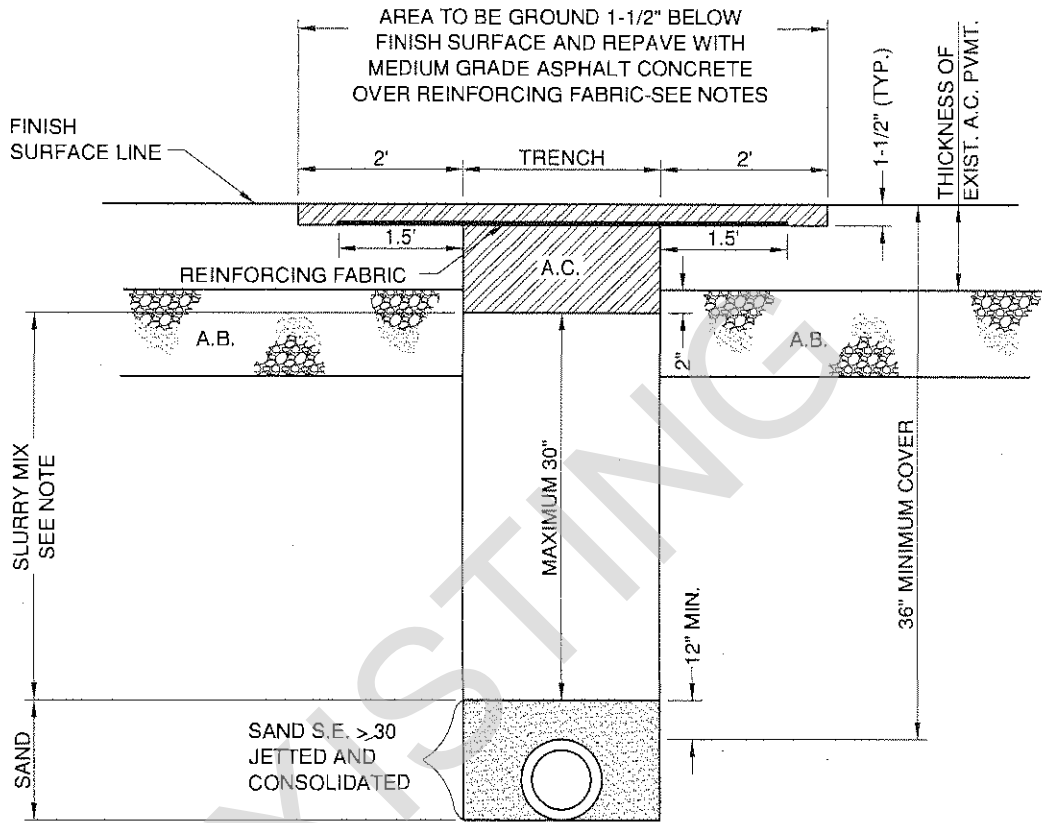

APPROVED:

*Manu Jousse*  
P.W. DIRECTOR / CITY ENGINEER



**City of Westminster**  
DEPARTMENT OF PUBLIC WORKS

STANDARD NUMBER

UTILITY EXCAVATION

609

REVISED DATE: 5/15/08

# STANDARD DRAWING # 609

## UTILITY EXCAVATION IN THE PUBLIC RIGHT OF WAY

The intent of these standards is to assure the best repair possible and reduce adverse impacts for the Public from road roughness, closures, and time to do work. IT MUST BE DONE SAFELY!

### Notes

1. **Slurry Backfill:** Use 1.5 sack slurry with two (2) percent calcium chloride. If steel pipe is used then use non-chloride accelerator. Slurry shall be a maximum of thirty (30) inches deep, and shall be placed to the depth of two (2) inches below existing A.C. pavement.
  
2. **Pavement:** The trench shall be paved for the thickness of the existing paving plus a depth of two (2) inches, twenty-four (24) hours after slurry has been placed. The A.C. pavement shall be placed directly over the slurry with no aggregate base. The A.C. pavement in the trench plus two (2) feet each side of the trench, shall be ground a depth of one and one-half (1.5) inches below finish surface, and paved with a medium grade A.C. over reinforcing fabric.  

Latex rubber asphalt concrete or other type of asphalt concrete material may be required based on existing conditions.
  
3. **Reinforcing Fabric:** The trench, plus one and one-half (1.5) feet on each side, shall be covered with reinforcing fabric prior to paving.
  
4. **Cold Mix:** Use of cold mix (UPM) to temporarily repair excavations the same day, in order to allow traffic flow on smooth transitions, is generally allowable. If cold mix is to be used, use (UPM) or approved equal, following the City Engineer's approval. It shall be a minimum thickness of three (3) inches for residential streets and six (6) inches for arterial and secondary arterials, and kept in good and safe condition.
  
5. **Slurry Seal:** Longitudinal continuous excavation shall be sealed using Type II slurry seal and cracks sealed, for the width of any affected lanes following the A.C. repairs, to the satisfaction of the City Engineer.
  
6. **Sand:** Sand shall be used for bedding and as cover for installed pipes. A minimum cover of twelve (12) inches of sand shall be used. On water service laterals, maintain twelve (12) inches of sand above the lateral, even when the elevation varies as the lateral is closer to the edge of gutter. Sand shall have an sand equivalence of greater than or equal to thirty (30). Sand shall be placed in maximum one foot lifts or less thickness as necessary to be able to achieve the necessary consolidation. It shall be jetted and consolidated to the satisfaction of the City Engineer.
  
7. **NPDES Requirements:** Streets shall be kept clean at all times. The City may require mechanical sweeping. The contractor shall maintain a clean work area, and prevent any material prohibited by the NPDES permit and the City's Water Quality Ordinance from entering the storm drain system.  

The contractor shall meet all NPDES requirements during construction. All erosion control measures shall be taken during construction, to the satisfaction of the City Engineer. If no proper erosion control measures are taken on site, City may require that all operations cease and the encroachment permit may be revoked until proper measures have been taken to the satisfaction of the City Engineer.
  
8. **Traffic Control Plan:** Contractor (or applicant) shall submit traffic control plans complying with the California Manual on Uniform Traffic Control Devices (MUTCD), in advance for review and approval prior to excavating within the Public Right of Way, unless the excavation is an emergency, and then comply with the WATCH Manual.

**STANDARD DRAWING # 609**  
**UTILITY EXCAVATION IN THE PUBLIC RIGHT OF WAY**  
**Notes (Continued)**

9. **CAL-OSHA:** Contractor shall follow and will be responsible to obtain a Cal-OSHA permit when required.
10. **Steel Plates:** When steel plates are used, they shall be used per Caltrans Standards, with the following modification: Method Two (2) shall be applied to all arterial and secondary arterials. Steel plates shall be doweled into the ground, and/or welded together to eliminate movement. The City Engineer may recommend additional safety measures if it is deemed necessary. Steel plates shall always have cold mix around all edges. Recessing of steel plates shall be performed as required by the City Engineer on arterial and secondary arterial streets for planned activities requiring more than twenty-four (24) hours for open travel ways.
- a) **Planned activity:** Planned activities shall be cleared through the Engineering Division to be working in the Public Right of Way under an approved schedule. Steel plates can remain at one location for twenty-four (24) hours, then shall be removed. If unforeseen conditions arise, then follow emergency procedures below.
- b) **Emergency procedures:** When an unforeseen condition arises, steel plates can be maintained at a location for up to seventy-two (72) hours.
11. **Potholing/Temporary Excavating:** If potholing is the result of an investigation for a planned activity or for temporary excavations, cold mix (UPM) or approved equal could be used temporarily with suitable backfill, flush with adjacent existing asphalt. Following completion of the activity, standard excavation for permanent repair shall be followed. This will be done the same day as the excavation to reduce adverse impacts to roadway use. The City Engineer may require, based on the existing street condition, that excavation repair includes grinding along the edges, as per standard utilities excavation repair.
12. **Boring:** Boring shall be considered as a continuous trench as far as excavation repair. Potholes located intermittently will not be treated as separate excavations but as a continuous excavation. The City shall reserve the right to require boring or open trench as the situation may arise, to the satisfaction of the City Engineer.
13. **Moratorium on Newly Resurfaced Streets:** Excavation shall generally not be permitted in any street that has been resurfaced in the past five years. No permit will be granted to excavate in the Public Right of Way except for lateral extensions to customers/repairs less than one thousand five hundred (1,500) feet, or as approved by the City Council. Approved excavations in new streets shall require full lane or full width of the street, as determined by the City Engineer, with grind and overlay repairs. In case of an emergency, applicant shall obtain the City Engineer's approval for appropriate repair measures as soon as possible.
14. **Contractor Identification:** Anyone working within the Public Right of Way shall be identified with the entity's name, to be visible from both directions of travel lanes.
15. **Variances:** The City Engineer may consider variances as requested in advance, that meet the intent of these specifications.
16. **Lane Closure:** Multiple lane closures will normally be prohibited.
17. **Work Hours:** Arterial and secondary arterial streets work hours shall be restricted to 9:00 a.m. until 3:00 p.m. No traffic control shall be placed before 9:00 am and shall be removed by 3:00 p.m. Residential and secondary streets work hours shall be restricted to 7:00 a.m. until 4:00 p.m.

**STANDARD DRAWING # 609**  
**UTILITY EXCAVATION IN THE PUBLIC RIGHT OF WAY**  
**Notes (Continued)**

18. **Insurance:** Anyone working within the Public Right of Way shall comply with the City's insurance requirements, prior to obtaining an encroachment permit.
19. **Encroachment Permit:** Anyone excavating within the Public Right of Way shall be required to obtain an encroachment permit prior to start of any excavation.
20. **Underground Service Alert:** Section 4216/4217 of the Government Code requires a DigAlert Identification Number be issued before an "Encroachment Permit" will be valid. For your DigAlert I.D. Number, Call Underground Service Alert, Toll Free: 1-800-422-4133, two working days before you dig.

**CALTRANS STANDARD**  
**TEMPORARY STEEL PLATE BRIDGING WITH A NON-SKID SURFACE**

Highway encroachment work involving excavations shall be identified during the review process of the permit applications package. It is recognized that to accommodate excavation work, steel plate bridging may be necessary. All permit conditions for use of steel plate bridging should be set forth in the special provisions of the permit.

Consideration of steel plate bridging in the review process should take into account the following factors:

1. Traffic volume and composition
2. Duration and size of the proposed excavation
3. Weather conditions

When it is determined in the review process that shoring will be a part of the permitted operation, the shoring shall conform to Caltrans standards.

When backfilling operations of an excavation in the traveled way, whether transverse or longitudinal, cannot be properly completed within a work day, steel plate bridging with a non-skid surface and shoring may be required to preserve unobstructed traffic flow. In such cases, the following conditions shall apply:

1. Steel plate bridging on freeways is not allowed.
2. Steel plates used for bridging must extend a minimum of twelve (12) inches beyond the edges of the trench.
3. Steel plate bridging shall be installed to operate with minimum noise.
4. The trench shall be adequately shored, per Caltrans Standards, to support the bridging and traffic loads.
5. Temporary paving with cold asphalt concrete shall be used to feather the edges of the plates, if plate installation by Method Two (2) is used.
6. Bridging shall be secured against displacement by using adjustable cleats, shims or other devices.

As required by Caltrans, steel plate bridging and shoring shall be installed using either Method One (1) or Two (2):

**Method One (1) For speeds more than 45 mph:**

The pavement shall be cold planed to a depth equal to the thickness of the plate and to a width and length equal to the dimensions of the plate.

**Method Two (2) For speeds 45 mph or less:**

Approach plate(s) and ending plate (if longitudinal placement) shall be attached to the roadway by a minimum of two (2) dowels pre-drilled into the corners of the plate and drilled two (2) inches into the pavement. Subsequent plates are butted to each other. Fine graded asphalt concrete shall be compacted to form ramps, maximum slope eighty-five (85) percent with a minimum twelve (12) inches taper to cover all edges of the steel plates. When steel plates are removed, the dowel holes in the pavement shall be backfilled with either graded fine or asphalt concrete mix, concrete slurry, or equivalent slurry satisfactory to the Caltrans' representative.

The contractor shall be responsible for maintenance of the steel plates, shoring and asphalt concrete ramps.

Unless specifically noted in the provisions of the permit, steel plate bridging should not exceed four (4) consecutive working days in any given week. Backfilling of excavations shall be covered with a minimum three (3) inches temporary layer of cold asphalt concrete.

The following table shows the required minimal thickness of steel plate bridging required for a given trench width:

TRENCH WIDTH	MINIMUM PLATE THICKNESS
0.3 m (1.0')	13 mm (1/2")
0.45 m (1.5')	19 mm (3/4")
0.6 m (2.0')	22 mm (7/8")
0.9 m (3.0')	25 mm (1")
1.2 m (4.0')	32 mm (1 1/4")

NOTE: For spans greater than four (4) feet, a structural design shall be prepared by a registered Civil Engineer and approved by Caltrans.

Steel plate bridging shall be steel plates designed for HS20.44 truck loading per Caltrans Bridge Design Specifications Manual. The permittee shall maintain on the steel plate a non-skid surface having a minimum coefficients of friction equivalent to 035 as determined by California Test Method 342 (see Caltrans Standards). If a different test method is used, the permittee may utilize standard test plates with known coefficients of friction available from each Caltrans District Materials Engineer to correlate skid resistance result to California Test Method 342.

A Rough Road Sign (W33) with black lettering on an orange background, may be used in advance of steel plate bridging. This is to be used with any other required construction signing.

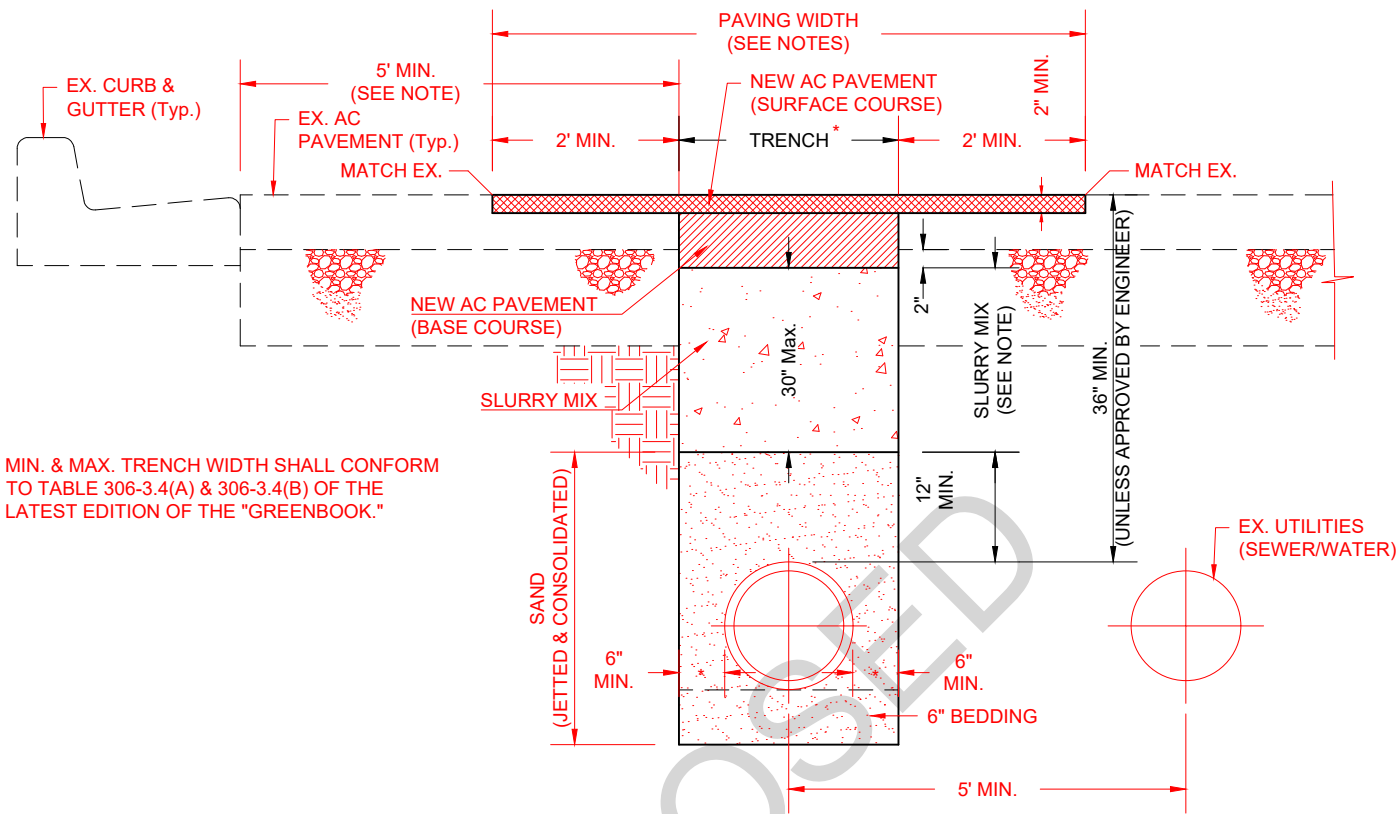

MIN. & MAX. TRENCH WIDTH SHALL CONFORM TO TABLE 306-3.4(A) & 306-3.4(B) OF THE LATEST EDITION OF THE "GREENBOOK."

**NOTES:**

1. ALL PAVEMENT REMOVALS SHALL BE PERFORMED USING STRAIGHT-LINE SAW CUTS AT A MINIMUM DEPTH OF 2 INCHES.
2. IF THE TRENCH IS LESS THAN 5 FEET FROM THE EDGE OF THE CURB & GUTTER OR ADJACENT PATCH, THE EXISTING PAVEMENT SHALL BE REMOVED TO THE CUT LINES OR EDGES, OR AS DIRECTED BY CITY ENGINEER.
3. EXCAVATION SHALL COMPLY WITH THE PROVISIONS OUTLINED IN SUBSECTIONS 306-3, "TRENCH EXCAVATION," 306-4, "SHORING AND BRACING," AND 306-5, "DEWATERING," OF THE LATEST EDITION OF THE "GREENBOOK."
4. DURING EXCAVATION AND SUBGRADE PREPARATION, THE CONTRACTOR SHALL TAKE ALL NECESSARY MEASURES TO PROTECT ALL IMPROVEMENTS, WHETHER PUBLIC OR PRIVATE, INCLUDING UTILITIES AND THEIR SERVICES, FROM POTENTIAL DAMAGE RESULTING FROM THE CONTRACTOR'S OPERATIONS.
5. BACKFILL AND DENSIFICATION SHALL CONFORM TO THE APPLICABLE REQUIREMENTS OUTLINED IN SUBSECTIONS 201-6, "CONTROLLED LOW STRENGTH MATERIAL (CLSM)," 217-1, "BEDDING AND BACKFILL MATERIALS," AND 306-6, "BEDDING" OF THE LATEST EDITION OF "GREENBOOK."
6. ASPHALT PAVEMENT SHALL BE CONSTRUCTED IN ACCORDANCE WITH SUBSECTIONS 203-6, "ASPHALT CONCRETE," AND 302-5, "ASPHALT CONCRETE PAVEMENT," OF THE LATEST EDITION OF THE "GREENBOOK."
7. THE SURFACE COURSE AND BASE COURSE ASPHALT CONCRETE PAVEMENT SHALL CONSIST OF THE SAME MIX AS THE EXISTING ASPHALT CONCRETE PAVEMENT(S), OR AS DIRECTED BY THE CITY ENGINEER.
8. TEMPORARY RESURFACING SHALL BE INSTALLED PROMPTLY ONCE THE BACKFILL CONDITION IS DEEMED APPROPRIATE BY THE CITY ENGINEER. TEMPORARY PAVEMENT REPLACEMENT SHALL BE PLACED AT THE CONTRACTOR'S EXPENSE. IT SHALL BE LEVEL WITH THE EXISTING PAVEMENT ON COMPACTED TRENCH BACKFILL AND MUST BE AT LEAST FOUR (4) INCHES THICK FOR RESIDENTIAL STREETS AND SIX (6) INCHES THICK FOR ARTERIAL ROADWAYS.
9. PERMANENT PAVEMENT RESURFACING SHALL BE COMPLETED WITHIN TWO (2) WEEKS FOLLOWING THE BACKFILLING OF TRENCHES, AND SOLELY AFTER SETTLEMENT HAS BEEN ACHIEVED AND THE FILL SURFACE HAS ADEQUATELY DRIED.
10. MANHOLE FRAMES, SHAFTS, AND CONCRETE VERTICAL SURFACES SHALL RECEIVE A TACK COAT PRIOR TO THE PLACEMENT OF PERMANENT ASPHALT TRENCH RESURFACING.

APPROVED BY:

---

VINNY T. HOANG  
CITY ENGINEER

ADOPTED DATE: MAY 13, 2026



**City of Westminster**  
DEPARTMENT OF PUBLIC WORKS

**UTILITY EXCAVATION & POTHOLING DETAIL**

STANDARD PLAN NO.  
**609**  
SHEET 1 OF 5

## NOTES:

THE PURPOSE OF THESE STANDARDS IS TO ENSURE THE HIGHEST QUALITY OF REPAIRS AND TO MINIMIZE ADVERSE EFFECTS ON THE PUBLIC ARISING FROM ROAD ROUGHNESS, CLOSURES, AND WORK DELAYS. IT MUST BE DONE SAFELY!

**1. SLURRY BACKFILL:**

UTILIZE A 1-SACK SLURRY MIXED WITH TWO (2) PERCENT CALCIUM CHLORIDE. IF A STEEL PIPE IS EMPLOYED, A NON-CHLORIDE ACCELERATOR SHOULD BE USED. THE SLURRY SHALL NOT EXCEED A DEPTH OF THIRTY (30) INCHES AND MUST BE APPLIED TO A LEVEL TWO (2) INCHES BELOW THE EXISTING ASPHALT PAVEMENT.

**2. SLURRY SEALED STREET:**

COMPLETED PAVEMENT SHALL BE SEALED USING TYPE II SLURRY SEAL ACROSS THE WIDTH OF ANY AFFECTED LANES, FOLLOWING THE A.C. REPAIRS, TO THE SATISFACTION OF THE CITY ENGINEER.

**3. SAND BEDDING & BACKFILL:**

UNLESS APPROVED BY THE ENGINEER, SAND SHALL BE USED FOR BEDDING AND AS A COVER FOR INSTALLED PIPELINES. A MINIMUM OF TWELVE (12) INCHES OF SAND IS REQUIRED. FOR WATER SERVICE LATERALS, MAINTAIN AT LEAST TWELVE (12) INCHES OF SAND ABOVE THE LATERAL, EVEN IF THE ELEVATION VARIES AS THE LATERAL APPROACHES THE EDGE OF THE GUTTER. THE SAND SHALL HAVE A SAND EQUIVALENCE (S.E.) OF AT LEAST 20. PLACEMENT OF SAND SHALL BE IN MAXIMUM LIFTS OF ONE FOOT OR IN LAYERS AS NEEDED TO ENSURE PROPER COMPACTION. THE SAND SHALL BE JET-EDGED AND COMPACTED TO 90% RELATIVE COMPACTION.

**4. NPDES REQUIREMENTS:**

STREETS SHALL BE KEPT REASONABLY CLEAN AT ALL TIMES. THE CITY RESERVES THE RIGHT TO MANDATE THE IMPLEMENTATION OF MECHANICAL SWEEPING PROCEDURES. THE CONTRACTOR SHALL ENSURE A CLEAN WORK ENVIRONMENT AND TAKE APPROPRIATE MEASURES TO PREVENT ANY MATERIALS RESTRICTED BY THE NPDES PERMIT AND THE CITY'S WATER QUALITY ORDINANCE FROM ENTERING THE STORM DRAIN SYSTEM.

COMPLIANCE WITH NPDES REGULATIONS AND STANDARDS IS MANDATORY. THE CONTRACTOR SHALL IMPLEMENT, INSPECT, AND MAINTAIN AN EFFECTIVE COMBINATION OF BEST MANAGEMENT PRACTICES (BMPs) FOR EROSION AND SEDIMENT CONTROL, NON-STORMWATER MANAGEMENT, AND MATERIAL MANAGEMENT THROUGHOUT THE DURATION OF THE PROJECT, INCLUDING, BUT NOT LIMITED TO, ANY PERIODS OF TEMPORARY WORK SUSPENSION.

THE CONTRACTOR IS REQUIRED TO PROACTIVELY MODIFY BEST MANAGEMENT PRACTICES (BMPs) AS NECESSARY TO ACCOMMODATE CHANGING WEATHER CONDITIONS, EVOLVING CONSTRUCTION ACTIVITIES, AND SITE-SPECIFIC REQUIREMENTS, THEREBY ENSURING CONTINUOUS COMPLIANCE.

IF SUFFICIENT EROSION CONTROL MEASURES ARE NOT IMPLEMENTED ON THE SITE, THE CITY RETAINS THE RIGHT TO SUSPEND ALL OPERATIONS AND REVOKE THE ENCROACHMENT PERMIT UNTIL THE NECESSARY MEASURES, AS EVALUATED AND APPROVED BY THE CITY ENGINEER, ARE PROPERLY ENFORCED.

**5. TRAFFIC CONTROL PLAN:**

CONTRACTOR (OR APPLICANT) SHALL SUBMIT TRAFFIC CONTROL PLANS IN ACCORDANCE WITH THE CALIFORNIA MANUAL ON UNIFORM TRAFFIC CONTROL DEVICES (MUTCD) AT LEAST FOURTEEN DAYS PRIOR TO THE COMMENCEMENT OF EXCAVATION WITHIN THE PUBLIC RIGHT OF WAY FOR REVIEW AND APPROVAL. IN THE EVENT OF AN EMERGENCY, COMPLIANCE WITH THE WATCH MANUAL IS MANDATED.

**6. CAL-OSHA:**

CONTRACTOR SHALL FOLLOW AND WILL BE RESPONSIBLE FOR OBTAINING A CAL-OSHA PERMIT WHEN REQUIRED.

**7. STEEL PLATES:**

WHEN STEEL PLATES ARE USED, THEY SHALL CONFORM TO CALTRANS STANDARDS, WITH THE FOLLOWING MODIFICATION: METHOD TWO (2) SHALL BE USED FOR ALL ARTERIAL AND SECONDARY ARTERIAL ROADS. STEEL PLATES SHALL BE ANCHORED TO THE GROUND AND/OR WELDED TOGETHER TO PREVENT MOVEMENT. THE CITY ENGINEER MAY RECOMMEND ADDITIONAL SAFETY MEASURES IF NECESSARY. STEEL PLATES SHALL HAVE COLD-MIX TRANSITION ON ALL EDGES. RECESSING OF STEEL PLATES SHALL BE DONE AS REQUIRED BY THE CITY ENGINEER ON ARTERIAL AND SECONDARY ARTERIAL STREETS FOR PLANNED ACTIVITIES REQUIRING MORE THAN TWENTY-FOUR (24) HOURS FOR OPEN TRAVEL WAYS.

**PLANNED ACTIVITY:** ALL PLANNED ACTIVITIES MUST BE AUTHORIZED BY THE ENGINEERING DIVISION PRIOR TO COMMENCING WORK WITHIN THE PUBLIC RIGHT OF WAY, ADHERING TO AN APPROVED SCHEDULE. STEEL PLATES ARE PERMITTED TO REMAIN AT A SINGLE LOCATION FOR A MAXIMUM OF TWENTY-FOUR (24) HOURS BEFORE REMOVAL IS REQUIRED. IN THE EVENT OF UNFORESEEN CIRCUMSTANCES, THE EMERGENCY PROCEDURES OUTLINED BELOW SHOULD BE FOLLOWED.

APPROVED BY:

VINNY T. HOANG  
CITY ENGINEER

ADOPTED DATE: MAY 13, 2026



City of Westminster  
DEPARTMENT OF PUBLIC WORKS

UTILITY EXCAVATION &  
POTHOLING DETAIL

STANDARD PLAN NO.

609

SHEET 2 OF 5

EMERGENCY PROCEDURES: IN THE EVENT OF AN UNFORESEEN CIRCUMSTANCE, STEEL PLATES MAY BE RETAINED AT A SPECIFIED LOCATION FOR A DURATION NOT EXCEEDING SEVENTY-TWO (72) HOURS.

**8. POTHOLING/TEMPORARY EXCAVATING:**

IF POTHOLING RESULTS FROM AN INVESTIGATION RELATED TO A PLANNED ACTIVITY OR TEMPORARY EXCAVATIONS, EITHER COLD MIX (UPM) OR AN APPROVED EQUIVALENT MAY BE UTILIZED TEMPORARILY, WITH APPROPRIATE BACKFILL THAT IS FLUSH WITH THE ADJOINING EXISTING ASPHALT. UPON COMPLETION OF THE ACTIVITY, STANDARD PROCEDURES FOR EXCAVATION AND PERMANENT RESTORATION/REPAIR PER DETAIL ON SHEET 1 OF STANDARD PLAN NO. 609 SHALL BE FOLLOWED. THIS PROCESS SHALL BE CONDUCTED ON THE SAME DAY AS THE EXCAVATION TO MINIMIZE NEGATIVE IMPACTS ON ROADWAY USAGE.

**9. BORING:**

BORING SHALL BE REGARDED AS A CONTINUOUS TRENCH FOR THE PURPOSE OF EXCAVATION REPAIR. POTHLES SITUATED INTERMITTENTLY WILL NOT BE CLASSIFIED AS SEPARATE EXCAVATIONS BUT WILL BE REGARDED AS A SINGLE, CONTINUOUS EXCAVATION. THE CITY RESERVES THE RIGHT TO MANDATE EITHER BORING OR OPEN TRENCH EXCAVATION AS DEEMED APPROPRIATE BY THE CIRCUMSTANCES, TO THE SATISFACTION OF THE CITY ENGINEER.

**10. MORATORIUM ON NEWLY RESURFACED STREETS:**

EXCAVATION SHALL GENERALLY NOT BE PERMITTED IN ANY STREET THAT HAS BEEN RESURFACED IN THE PAST FIVE YEARS.

IF APPROVED BY THE CITY ENGINEER, EXCAVATIONS OR POTHOLING ON NEW STREETS MUST INCLUDE GRINDING AND OVERLAY OF FULL-LANE OR FULL-WIDTH OF THE STREET, AS DETERMINED BY THE CITY ENGINEER.

IN EMERGENCY SITUATIONS, THE APPLICANT SHALL SEEK THE APPROVAL OF THE CITY ENGINEER FOR SUITABLE REPAIR MEASURES AT THE EARLIEST POSSIBLE CONVENIENCE.

**11. CONTRACTOR IDENTIFICATION:**

ANYONE WORKING WITHIN THE PUBLIC RIGHT OF WAY SHALL BE IDENTIFIED WITH THE ENTITY'S NAME, TO BE VISIBLE FROM BOTH DIRECTIONS OF TRAVEL LANES.

**12. VARIANCES:**

CITY ENGINEER MAY CONSIDER VARIANCES AS REQUESTED IN ADVANCE THAT MEET THE INTENT OF THESE SPECIFICATIONS.

**13. LANE CLOSURE:**

MULTIPLE LANE CLOSURES WILL GENERALLY BE PROHIBITED.

**14. WORK HOURS:**

WORK HOURS FOR ARTERIAL AND SECONDARY ARTERIAL STREETS SHALL BE LIMITED TO 9:00 A.M. TO 4:00 P.M. NO TRAFFIC CONTROL MEASURES SHALL BE IMPLEMENTED BEFORE 9:00 AM AND MUST BE REMOVED BY 4:00 P.M. WORK HOURS FOR RESIDENTIAL AND SECONDARY STREETS SHALL BE RESTRICTED TO 7:00 A.M. TO 4:00 P.M.

**15. INSURANCE:**

ANY INDIVIDUAL OPERATING WITHIN THE PUBLIC RIGHT OF WAY MUST ADHERE TO THE CITY'S INSURANCE PREREQUISITES PRIOR TO SECURING AN ENCROACHMENT PERMIT.

**16. ENCROACHMENT PERMIT:**

ANYONE CONDUCTING EXCAVATIONS WITHIN THE PUBLIC RIGHT OF WAY MUST OBTAIN AN ENCROACHMENT PERMIT PRIOR TO COMMENCING ANY EXCAVATION ACTIVITIES.

**17. UNDERGROUND SERVICE ALERT:**

SECTION 4216/4217 OF THE GOVERNMENT CODE MANDATES THAT A DIGALERT IDENTIFICATION NUMBER BE ISSUED PRIOR TO THE VALIDITY OF AN "ENCROACHMENT PERMIT." FOR YOUR DIGALERT ID NUMBER, PLEASE CONTACT UNDERGROUND SERVICE ALERT AT 1-800-422-4133, AT LEAST TWO WORKING DAYS BEFORE COMMENCEMENT OF EXCAVATION.

APPROVED BY:

VINNY T. HOANG  
CITY ENGINEER

ADOPTED DATE: MAY 13, 2026



**City of Westminster**

DEPARTMENT OF PUBLIC WORKS

**UTILITY EXCAVATION &  
POTHOLING DETAIL**

STANDARD PLAN NO.

**609**

SHEET 3 OF 5

# TEMPORARY STEEL PLATE BRIDGING WITH A NON-SKID SURFACE

HIGHWAY ENCROACHMENT WORK INVOLVING EXCAVATIONS SHALL BE IDENTIFIED DURING THE REVIEW PROCESS OF THE PERMIT APPLICATION PACKAGE. IT IS ACKNOWLEDGED THAT, TO ACCOMMODATE EXCAVATION ACTIVITIES, STEEL PLATE BRIDGING MAY BE REQUIRED. ALL CONDITIONS RELATED TO THE USE OF STEEL PLATE BRIDGING SHOULD BE EXPLICITLY INCLUDED IN THE SPECIAL PROVISIONS OF THE PERMIT.

THE CONSIDERATION OF STEEL PLATE BRIDGING DURING THE REVIEW PROCESS OUGHT TO ENCOMPASS THE FOLLOWING FACTORS:

1. TRAFFIC VOLUME AND COMPOSITION
2. DURATION AND SIZE OF THE PROPOSED EXCAVATION
3. WEATHER CONDITIONS

WHEN THE REVIEW PROCESS CONCLUDES THAT SHORING IS INCLUDED IN THE AUTHORIZED OPERATIONS, THE SHORING SHALL ADHERE TO CALTRANS STANDARDS.

DURING BACKFILLING OPERATIONS OF AN EXCAVATION WITHIN THE TRAVELED WAY, WHETHER TRANSVERSE OR LONGITUDINAL, IF IT CANNOT BE COMPLETED WITHIN A SINGLE WORKDAY, THE USE OF STEEL PLATE BRIDGING WITH A NON-SKID SURFACE AND SHORING WILL BE NECESSARY TO MAINTAIN UNOBSTRUCTED TRAFFIC FLOW. IN SUCH CASES, THE FOLLOWING CONDITIONS SHALL APPLY:

1. STEEL PLATES USED FOR BRIDGING MUST EXTEND AT LEAST TWELVE (12) INCHES BEYOND THE EDGES OF THE TRENCH.
2. STEEL PLATE BRIDGING SHALL BE INSTALLED TO OPERATE WITH MINIMAL NOISE.
3. THE TRENCH MUST BE PROPERLY SHORED, ACCORDING TO CALTRANS STANDARDS, TO SUPPORT THE BRIDGING AND TRAFFIC LOADS.
4. TEMPORARY PAVING WITH COLD ASPHALT CONCRETE SHALL BE APPLIED TO FEATHER THE EDGES OF THE PLATES IF USING METHOD TWO (2) FOR PLATE INSTALLATION.
5. BRIDGING SHALL BE SECURED AGAINST DISPLACEMENT BY USING ADJUSTABLE CLEATS, SHIMS, OR OTHER DEVICES.

STEEL PLATE BRIDGING AND SHORING SHALL BE INSTALLED USING EITHER METHOD ONE (1) OR TWO (2):

**METHOD ONE (1) FOR SPEEDS MORE THAN 45 MPH:**

THE PAVEMENT SHALL BE COLD-PLANNED TO A DEPTH EQUAL TO THE THICKNESS OF THE PLATE, WITH A WIDTH AND LENGTH CORRESPONDING TO THE PLATE'S DIMENSIONS.

**METHOD TWO (2) FOR SPEEDS 45 MPH OR LESS:**

THE APPROACH PLATE(S) AND ENDING PLATE (IF LONGITUDINAL PLACEMENT) SHALL BE AFFIXED TO THE ROADWAY USING A MINIMUM OF TWO (2) DOWELS PRE-DRILLED INTO THE CORNERS OF EACH PLATE, EXTENDING TWO (2) INCHES INTO THE PAVEMENT. SUBSEQUENT PLATES SHALL BE ALIGNED WITHOUT GAPS. FINE GRADED ASPHALT CONCRETE SHALL BE COMPACTED TO CREATE RAMPS, WITH A MAXIMUM SLOPE OF EIGHTY-FIVE (85) PERCENT AND A MINIMUM TWELVE (12) INCH TAPER TO ADEQUATELY COVER ALL EDGES OF THE STEEL PLATES. WHEN STEEL PLATES ARE REMOVED, THE DOWEL HOLES IN THE PAVEMENT SHALL BE BACKFILLED WITH EITHER GRADED FINE ASPHALT CONCRETE MIX, CONCRETE SLURRY, OR AN EQUIVALENT SLURRY ACCEPTABLE TO THE CALTRANS' REPRESENTATIVE.

THE CONTRACTOR SHALL BE RESPONSIBLE FOR MAINTENANCE OF THE STEEL PLATES, SHORING, AND ASPHALT CONCRETE RAMPS.

UNLESS EXPLICITLY SPECIFIED WITHIN THE PERMIT PROVISIONS, STEEL PLATE BRIDGING SHALL NOT EXCEED FOUR (4) CONSECUTIVE WORKING DAYS WITHIN ANY GIVEN WEEK. THE BACKFILLING OF EXCAVATIONS SHALL BE COVERED WITH A MINIMUM THREE (3) INCHES OF TEMPORARY LAYER OF COLD ASPHALT CONCRETE.

THE FOLLOWING TABLE SHOWS THE REQUIRED MINIMAL THICKNESS OF STEEL PLATE BRIDGING REQUIRED FOR A GIVEN TRENCH WIDTH:

TRENCH WIDTH (Feet)	MIN. PLATE THICKNESS (Inch)
1	1/2
1.5	3/4
2	7/8
3	1
4	1-1/4

NOTE: FOR SPANS EXCEEDING FOUR (4) FEET, A STRUCTURAL DESIGN MUST BE PREPARED BY A REGISTERED CIVIL ENGINEER.

APPROVED BY:

VINNY T. HOANG  
CITY ENGINEER

ADOPTED DATE: MAY 13, 2026



**City of Westminster**  
DEPARTMENT OF PUBLIC WORKS

UTILITY EXCAVATION &  
POTHOLING DETAIL

STANDARD PLAN NO.

**609**

SHEET 4 OF 5

STEEL PLATE BRIDGING SHALL CONSIST OF STEEL PLATES DESIGNED TO SUPPORT HS20.44 TRUCK LOADING IN ACCORDANCE WITH THE CALTRANS BRIDGE DESIGN SPECIFICATIONS MANUAL. THE PERMITTEE IS RESPONSIBLE FOR ENSURING THAT THE SURFACE OF THE STEEL PLATE IS NON-SKID, POSSESSING A MINIMUM COEFFICIENT OF FRICTION OF 0.35 AS DETERMINED BY CALIFORNIA TEST METHOD 342 (SEE CALTRANS STANDARDS). IF AN ALTERNATIVE TESTING METHOD IS EMPLOYED, THE PERMITTEE MAY USE STANDARD TEST PLATES WITH ESTABLISHED COEFFICIENTS OF FRICTION, AVAILABLE FROM EACH CALTRANS DISTRICT MATERIALS ENGINEER, TO CORRELATE SKID RESISTANCE RESULTS WITH THE SPECIFICATIONS OF CALIFORNIA TEST METHOD 342.

A ROUGH ROAD SIGN (W33) WITH BLACK LETTERING ON AN ORANGE BACKGROUND MAY BE USED IN ADVANCE OF STEEL PLATE BRIDGING. THIS IS TO BE USED WITH ANY OTHER REQUIRED CONSTRUCTION SIGNING.

PROPOSED

APPROVED BY:

VINNY T. HOANG  
CITY ENGINEER

ADOPTED DATE: MAY 13, 2026



**City of Westminster**  
DEPARTMENT OF PUBLIC WORKS

**UTILITY EXCAVATION &  
POTHOLING DETAIL**

STANDARD PLAN NO.

**609**

SHEET 5 OF 5

**Miscellaneous Standard Plan 610**  
**– Micro-Trench Detail (New)**

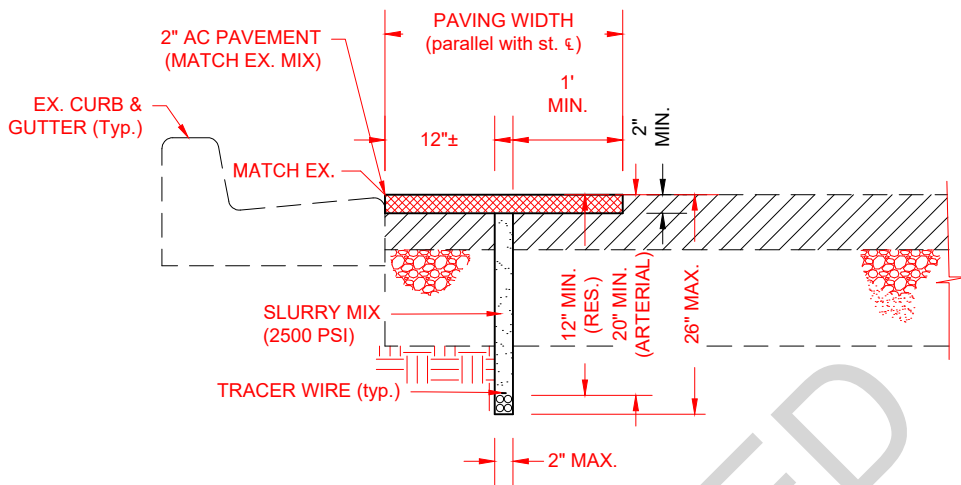

**NOTES:**

1. THE CONTRACTOR SHALL SUBMIT A DETAILED PLAN SHOWING THE PROPOSED CONDUIT ROUTES FOR THE CITY ENGINEER'S REVIEW AND APPROVAL. LATERAL INTERSECTIONS SHALL USE EITHER STANDARD OPEN TRENCH OR JACKING METHODS, WITH THE CHOSEN METHOD CLEARLY INDICATED ON THE PLANS, UNLESS PRE-APPROVED. THE FOLLOWING REQUIREMENTS SHALL BE CONSIDERED:
  - a) MICRO-TRENCHING IS TO BE USED ONLY FOR INSTALLING TELECOMMUNICATION CONDUITS AND IS LIMITED TO ONE (1) CUT PER SIDE OF THE STREET.
  - b) MICRO-TRENCHING IS NOT ALLOWED IN CONCRETE PAVEMENT, SIDEWALKS, OR DECORATIVE SURFACES.
  - c) MICRO-TRENCHES MUST HAVE CONTINUOUS, UNIFORM, STRAIGHT, AND NEAT EDGES.
  - d) WHERE THERE ARE BIKE LANES OR ROUTES, MICRO-TRENCH OUTSIDE THE WHEEL PATH AND OVERLAY THE ENTIRE LANE.
2. A UTILITY CLEARANCE FROM USA/811 IS REQUIRED BEFORE ANY TRENCHING ACTIVITIES.
3. ALL EXCAVATED MATERIALS MUST BE REMOVED WITH VACUUM METHODS; DEBRIS CANNOT BE LEFT ON THE ROADWAY OR SIDEWALK.
4. PEDESTRIAN ACCESS COMPLYING WITH ADA MUST BE MAINTAINED AT ALL TIMES.
5. AC PAVEMENT REPLACEMENT WILL HAPPEN NO SOONER THAN 48 HOURS AFTER SLURRY BACKFILL OF THE TRENCH AND MUST BE COMPLETED WITHIN 14 CALENDAR DAYS.
6. ASPHALT CONCRETE PAVEMENT SHALL MEET THE REQUIREMENTS OF SECTION 203-6, ASPHALT CONCRETE, OF THE LATEST EDITION OF THE "GREENBOOK."
7. NO OPEN TRENCH MAY BE LEFT UNATTENDED OR OPEN OVERNIGHT.
8. IF EXISTING UTILITIES ARE DAMAGED, THE CONTRACTOR SHALL IMMEDIATELY NOTIFY THE INSPECTOR, UTILITY OWNER AND PERFORM REPAIRS PROMPTLY TO UTILITY OWNER'S REQUIREMENTS.
9. THE USE OF HYDRO-JETTING IS NOT PERMITTED.
10. ANCHORS/SPACERS SHALL BE SPACED AT A MAXIMUM DISTANCE OF 10' FEET.

APPROVED BY:

VINNY T. HOANG  
CITY ENGINEER

ADOPTED DATE: MAY 13, 2026



**City of Westminster**  
DEPARTMENT OF PUBLIC WORKS

**MICRO-TRENCH DETAIL**

STANDARD PLAN NO.

**610**